

Area-Velocity Flow Meter

Measure Flow in Open Channels and Partially-Filled Pipes
No Flume or Weir Required

Area-Velocity Flow Meter

Model AVFM 6.1

Display, Transmit and Totalize
Flow in Open Channels and
Partially-Filled Pipes

No Flume or Weir Required
Three 4-20mA Outputs
Two Control Relays
Measures Reverse Flow
Modbus® RTU Optional



**Measures Velocity and Level to Monitor Flow
with a single Ultrasonic Sensor**

Area-Velocity Flow Meter

Measure flow through open channels, partially full pipes and surcharged pipes *without* a flume or weir. Ideal for wastewater stormwater, effluent, industrial wastewater, and irrigation water.

Submersible Ultrasonic Sensor

The AVFM 6.1 uses a submerged ultrasonic sensor to continuously measure both Velocity and Level in the channel. The sensor resists fouling, corrosion and abrasion. The flow meter can be configured with the standard submerged velocity-level sensor, or with submerged velocity plus a separate non-contacting ultrasonic level sensor, for highly aerated fluids or those with high concentration of suspended solids.



View flow rate and total flow on the large backlit LCD display and connect to external devices with three 4-20mA outputs and two control relays. Flow rate, volume, run hours, and diagnostic information available through the optional Modbus® RTU serial communications.

Ultrasonic Flow Monitor for Partially Filled Pipes & Open Channels

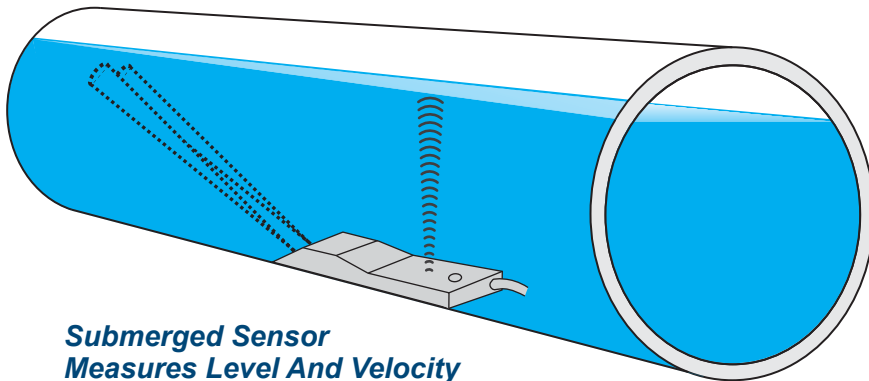

Submerged Sensor Measures Level And Velocity

Easy to Use

The AVFM 6.1 Area-Velocity Flow Meter measures both Level and Velocity to calculate flow in an open channel or pipe. Configuration is simple: enter the pipe diameter or channel dimensions and the AVFM 6.1 automatically computes and displays flow volume.

The ultrasonic sensor mounts inside the pipe or on the bottom of a channel with a stainless steel mounting bracket (included) and a single screw into the bottom of the pipe or channel. No special compounds, tools or hardware are required. The sensor is completely sealed with no orifices or ports.

The ultrasonic sensor mounts inside the pipe or on the bottom of a channel with a

Recommended Pipe or Channel Conditions

Careful selection of sensor mounting location results in best performance and maintenance-free operation. Avoid locations where sediment builds up.

Best possible accuracy will result when the water is not highly turbulent and where velocity is evenly distributed across the channel. The channel should not have drops or direction changes immediately upstream of the sensor mounting location. Pipe or channel slope should not exceed 3%. See installation manual for specific installation recommendations.

The AVFM 6.1 can measure forward flow velocity up to 20 ft/sec (6 m/sec) and reverse flow up to 5 ft/sec (1.5 m/sec). The electronics and software sample and average flow rates continuously to provide stable readings. The submerged velocity/level sensor will measure flow in partially full and surcharged pipes with pressure up to 10 psi. No special set-up or adjustment is required. Minimum recommended pipe diameter is 6" (150 mm).

Alternate Sensor Configurations

Alternate sensor models are available for special applications: a separate non-contacting ultrasonic level sensor with a submerged velocity sensor. Sensor cable can be extended up to 500 ft (150 m). Use this configuration for pipes or channels with high concentration of air or suspended solids.

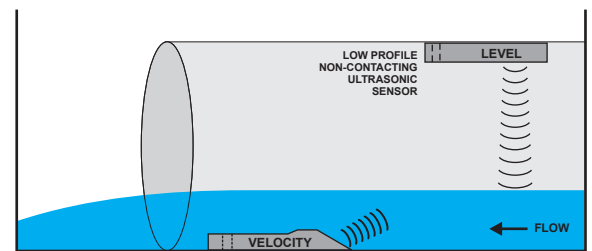

Custom Channel Shapes

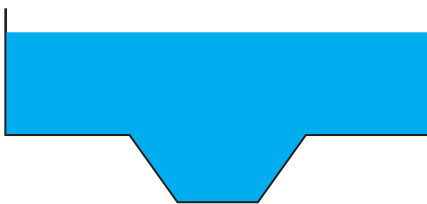

Configure the AVFM 6.1 for installation in irregular or compound channel shapes by entering the channel width at multiple level points through a simple menu. Channels of virtually any shape can be monitored with your choice of measurement units.

Standard 26 Million Point Data Logger

The AVFM 6.1 will store time and date-stamped flow values at 10 second to 60 minute intervals.

Daily flow reports are automatically created where total, minimum, maximum and average flow rates are displayed on the LCD display. Transfer log files and daily flow reports to any USB flash drive just by connecting to the logger's USB output. Windows software is included to display log files in graph and table formats, change measurement units and generate flow reports. Or, download data as .csv file format for import directly to Microsoft Excel.



AVFM 6.1 Specifications

General Specifications Greyline AVFM 6.1 Area-Velocity Flow Monitor

| | |
|---------------------------------------|---|
| Channel Types: | Round pipe, rectangular, trapezoid, egg or custom shapes |
| Electronics Enclosure: | Watertight and dust tight NEMA4X (IP 66) polycarbonate with clear, shatterproof cover |
| Accuracy: | Level: $\pm 0.25\%$ of reading or $\pm 0.08"$, whichever is greater. Repeatability & Linearity 0.1%. Velocity: $\pm 2\%$ of reading or ± 0.04 ft/sec, whichever is greater. Requires solids or bubbles minimum size of 100 microns, minimum concentration 75ppm. Repeatability & Linearity 0.5% |
| Display: | White, back-lit matrix - displays flow rate, totalizer, relay states, operating mode and calibration menu |
| Programming: | Built-in 5-key calibrator with English, French or Spanish language selection |
| Power Input: | 100-240VAC 50-60Hz, 10VA maximum. Optional: 9-32VDC, 10 WATTS maximum |
| Outputs: | 3 Isolated 4-20mA, 1000 ohm, (Flow, Level and Velocity) or 0-5VDC by menu selection |
| Control Relays: | 2 Relays, form 'C' dry contacts rated 5 amp SPDT; programmable for flow proportional pulse (sampler/totalizer), flow and/or level alarm |
| Data Logging: | Programmable 26 million point data capacity, time and date stamped plus formatted flow reports including Total, Average, Minimum, Maximum and times of occurrence. Includes USB output to Flash Drives and Windows software |
| Operating Temp. (electronics): | -5° to 140°F (-20° to 60°C) |
| Approximate Shipping Weight: | 10 Lbs. (4.5 Kg) |
| Approvals: | CE, CSA/UL/EN 61010-1 |

QZ02L Sensor

| | |
|------------------------------------|---|
| Velocity Measurement Range: | 0.1 to 20 ft/sec (0.03 to 6.2 m/sec) and reverse flow to -5 ft/sec (-1.5 m/sec) in fluids containing bubbles or solids with a minimum size of 100 microns and a minimum concentration of 75 ppm to act as acoustic reflectors |
| Level Measurement Range: | Minimum Head: 1 in (25.4 mm). Maximum Head: 15 ft. (4.57 m) |
| Operating Temperature: | 5 to 175°F (-15 to 80°C) |
| Exposed Materials: | 316 stainless steel, epoxy resin, polyurethane |
| Sensor Cable: | 25 Ft. (7.6 m) submersible polyurethane jacket, shielded, 3-coaxial |
| Sensor Mounting: | Includes MB-QZ stainless steel mounting bracket |
| Temperature Compensation: | Automatic, continuous |

Options

| | |
|---|--|
| Industrial Automation Protocols: | Modbus® RTU via RS-485 |
| Sensor Cable: | 50 ft. (15 m) or 100 ft. (30 m) submersible, continuous from Sensor - or splice up to total of 500 ft (150 m) length |
| Sensor Cable Junction Box: | Watertight NEMA4 polycarbonate with connection terminal strip |
| Enclosure Heater: | Thermostatically controlled to -40° F/C - recommended for temperatures below 32°F (0°C) |
| Intrinsic Safety Barriers: | For Sensor mounting in Class I,II,III, Div. I,II, Groups C,D,E,F,G hazardous locations |
| Sensors: | Separate non-contacting ultrasonic level sensor and submerged velocity sensor |
| Sensor Mounting Bands: | Stainless steel sensor mounting bands for pipes 6" to 72" (150 to 1800 mm) diameter |

Dimensions

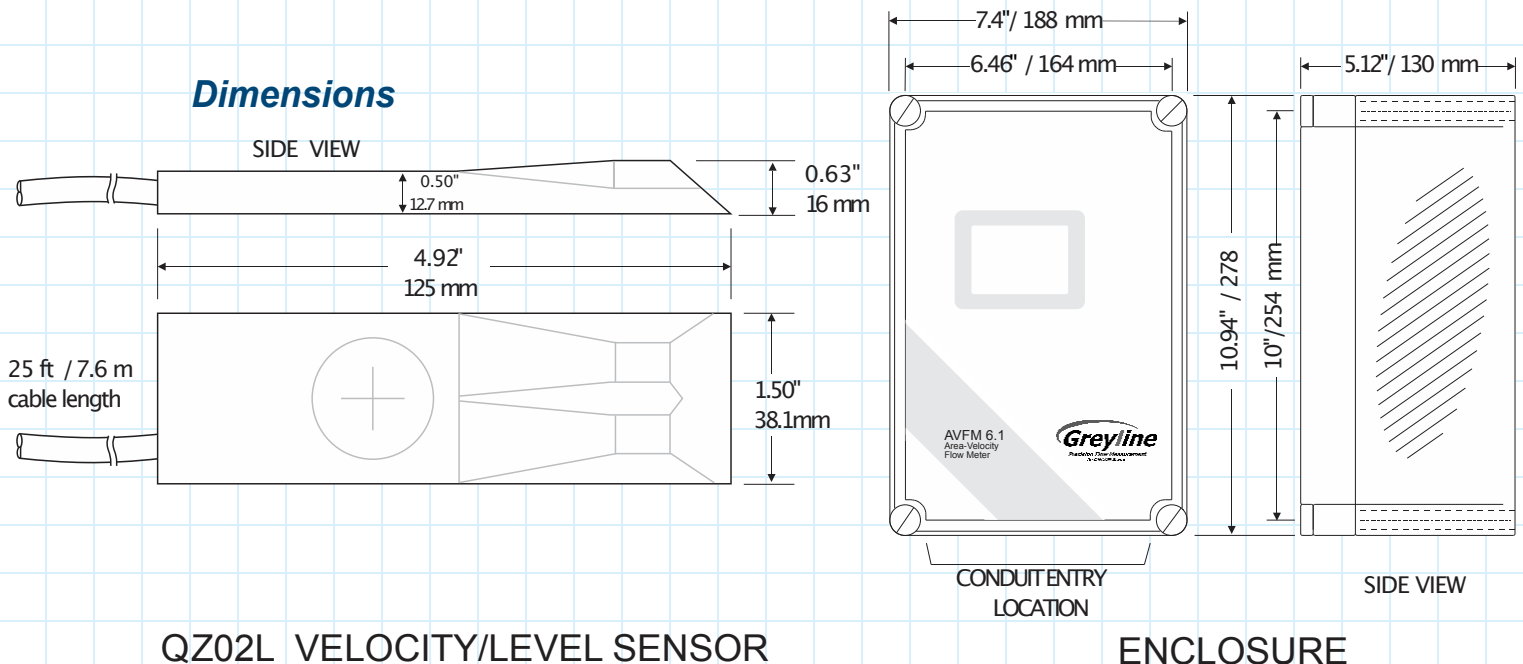

New Open Channel or Partially-Filled Pipe Flow Meter Measures Velocity and Level to calculate Flow



Recommended for:

-] Wastewater
-] Industrial Effluent
-] Stormwater
-] Combined Sewers
-] Natural Streams
-] Irrigation Water

AVFM 6.1 Area-Velocity Flow Meter

- ◆ Measure flow in pipes and open channels of any shape
- ◆ Ideal where flumes or weirs are difficult to install
- ◆ Works with water level from 1" (25.4 mm) to 15 ft (4.5 m)
- ◆ Auto-detects field installation of options serial communications and control relays.

The AVFM 6.1 Area-Velocity Flow Meter includes a submerged ultrasonic sensor that is installed at the bottom of an open pipe or channel. Exposed materials are stainless steel so the sensor resists fouling and corrosion. It has no moving parts and no orifices, ports or electrodes.

The AVFM 6.1 displays and totalizes flow. It includes three 4-20mA outputs (Flow, Level and Velocity), plus two control relays for level alarms or flow proportionate pulse output for samplers and chlorinators. It is easy to calibrate with the built-in keypad and menu system. A built-in 26 million point data logger with USB output is standard. Intrinsic Safety Barriers for sensor and cable installation in hazardous rated channels is also optional.

How to Order

Contact a Greyline sales representative in your area or phone one of our sales engineers. Describe your requirements and receive our prompt quotation.

Applications Support

Take advantage of Greyline's applications experience. Phone 1-888-473-9546 for advice and information on applications, installation or service for Greyline instruments.

No Risk Appraisal

The Greyline AVFM 6.1 Area-Velocity Flow Meter must meet your requirements. Discuss your application with a Greyline representative to arrange a 30-day trial.

The Greyline Guarantee

Quality of Materials and Workmanship - Each instrument manufactured by Greyline is warranted against defects in materials and workmanship for a period of one year from date of purchase. Refer to our limited warranty included with each product.



Montar Messtechnik BV

Groendahlscher Weg 118
D-46446 Emmerich am Rhein
Tel. +49 (0) 2822 965425-0

sales@montar-mt.com

HRB nr. 70937338

