

Insertion Flow Meter Series 454FTB-WGF

The KurzWGF single-point insertion flow meter for condensing gas environments includes the qualities and features found in all Kurz constant temperature thermal flow meters that make them outperform all other currently available thermal mass flow meters, including:

- The first thermal mass flow meter offering accurate and reliable condensing gas flow measurements (patent pending)
- Built-in dry gas flow calculation on all flow units for saturated processes
- Variable CH₄ composition for a CH₄/CO₂ gas mix
- Up to five user-selectable pure or mixed gas calibration curves
- The highest repeatability, accuracy, and reliability available
- The fastest response to temperature and velocity changes in the industry
- Constant temperature thermal technology
- Interchangeable sensor and electronics (single circuit board) — no matched sets
- Continuous self-monitoring electronics that verify the integrity of sensor wiring and measurements
- Zero velocity as a valid data point
- Sensor does not overheat at zero flow by using a unique constant temperature control method and power limiting design
- Completely field configurable using the local user interface or via a computer connection
- Supports HART, Profibus DP, and Modbus communication protocols
- User-programmable correction factors to compensate for velocity profiles
- Velocity-temperature mapping for wide ranging velocity and temperature
- User-programmable or auto-adjusting for shifting gas composition or multiple gas calibrations
- Sensor Blockage Correction Factor (SBCF)
- Flexibility with transmitter-attached or transmitter-separate designs
- Patented digital sensor control circuit (US 7,418,878)

Kurz Instruments is dedicated to manufacturing and marketing the best thermal mass flow meters available and to support our customers in their efforts to improve their businesses.

Applications

- Biogas
- Wastewater facilities
- Landfill sites
- Fogging in stacks
- Fan inlets
- EPA greenhouse gas emissions



Montar Messtechnik BV

Groendahlscher Weg 118
D-46446 Emmerich am Rhein
Tel. +49 (0) 2822 965425-0

sales@montar-mt.com

HRB nr. 70937338



SPECIFICATIONS

- **Velocity range**
0 to 4,000SFPM (18.6NMPS) (Air)
0 to 3,000SFPM (14 NMPS) (50/50Biogas)
0 to 2,000SFPM (9.3 NMPS) (CH₄)
Higher velocities available with reduced condensate immunity
- **Flow accuracy**(SCFM at laboratory conditions)
±(1% of reading +20SFPM)
- **0.25% reading repeatability**
- **Velocity time constant**
1.5 second for velocity changes at 4,000SFPM (constant temperature)
- **Process temperature time constant**
10 seconds for temp changes at 1,000SFPM (constant velocity)
- **Electronics operating temperature**
Integral display
-13°F to 149°F (-25°C to 65°C)
Remote aluminum display
-40°F to 149°F (-40°C to 65°C)
Remote polycarbonate display
-13°F to 122°F (-25°C to 50°C)

PROCESS CONDITIONS

- **Process pressure rating**
Up to 150PSIG (10 BARg)
- **Process temperature rating**
-40°F to 248°F (-40°C to 120°C)

APPROVALS

- **EPA mandatory GHG certification**
40 CFR 98.34(c)(1)
- **Alarm output conformity**
NAMUR NE43
- **European Union CE compliance**
EMC, LVD, PED, ROHS, and WEEE
- **Canadian Registration**
CRN
- **CSA, ATEX & IECEx approvals for Nonincendive, Flameproof, and Explosion-proof**
EN IEC 60079-0, EN IEC 60079-1
EN IEC 60079-15, Class I, Div 1 and 2

TRANSMITTER FEATURES

- **Aluminum (Type 4, IP66) dual chamber polyester powder-coated enclosure**
- **Adjustable display/keypad orientation**
- **Optically-isolated loop powered 4-20mA output** (±48VDC isolation)
12-bit resolution and accuracy
Maximum loop resistance is 300Ω at 18VDC, 550Ω at 24VDC, 1400Ω at 36VDC
- **Input power**
AC (85-264V 50/60 Hz, 24 watts max.)
or DC (24V ±10%), 1A max.
- **Integral or remote user interface**
- **Easy-to-use interface**
- **Backlit display / keypad**
2-lines of 16-characters each
- **User-configurable flow display (scrolling or static)**
- **User-configurable English or metric units for mass flow rate, mass velocity, and process temperature**
oC, oF, KGH, KGM, NCMH, NLPM, NMPS, PPH, PPM, SCFH, SCFM, SCMh, SFPM, SLPM, SMPS
- **Velocity-dependent correction factors for flow rate**
- **Built-in dry gas flow calculation for saturated processes**
- **Two optically isolated solid-state relays / alarms**
Configurable as alarm outputs or pulsed totalizer output, or air purge cleaning
- **Built-in zero-mid-spandrift check**
- **Built-in flow totalizers and elapsed time**
- **User-configurable digital filtering from 0 to 600 seconds**
- **Configuration/data access**
USB or RS-485 Modbus (ASCII or RTU)
- **Meter memory**
200 recent events, top 20 min/max, and 56 hours (10 second samples of trends)
- **3-year warranty**

SUPPORT & ELEMENT COMPONENTS

- **Sensor material**
C-276 alloy all-welded sensor construction (standard)
- **Sensor support**
316L stainless steel (standard)
C-276 alloy (optional)
- **Sensor support diameter**
3/4" and 1" (19 mm and 25 mm)
- **Sensor support length**
6" to 60" (152 mm to 1524 mm)
- **3-year warranty**

OPTIONS

- **Enclosures**
Aluminum, stainless steel, or polycarbonate (remote only)
- **Multiple gas calibrations with up to five curves loaded in memory**
- **User-defined binary gas composition**
- **Communication protocols**
HART (v7 FSK) and PROFIBUS DP
- **One 4-20mA non-isolated analog input**
- **Flow valve PID controller and configurable control application**
Permits controlling set point velocity or flow rate through available control valve, damper, or 4-20mA interface
- **Digital input dedicated to purge and zero-mid-spandrift check**
- **Pulsed output as a remote flow totalizer**
- **Hardware accessories**
Available hardware includes flanges, ball valves, restraints, retractors, cable glands, conduit seals, cable, compression fittings, packing glands, and branch fittings





SERIES 454FTB-WGF OUTLINE DRAWINGS

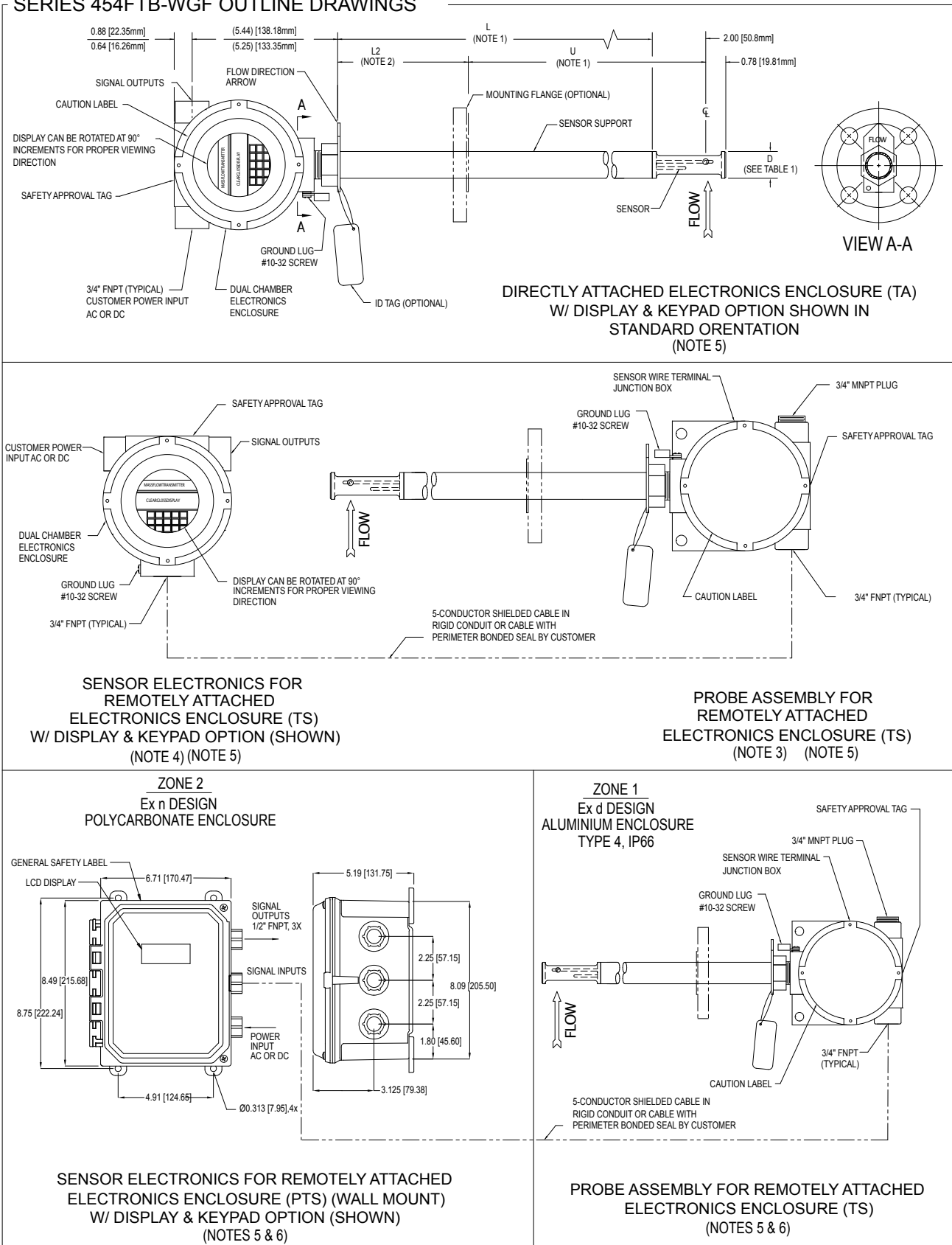



SERIES 454FTB-WGF OUTLINE DRAWINGS (cont'd)

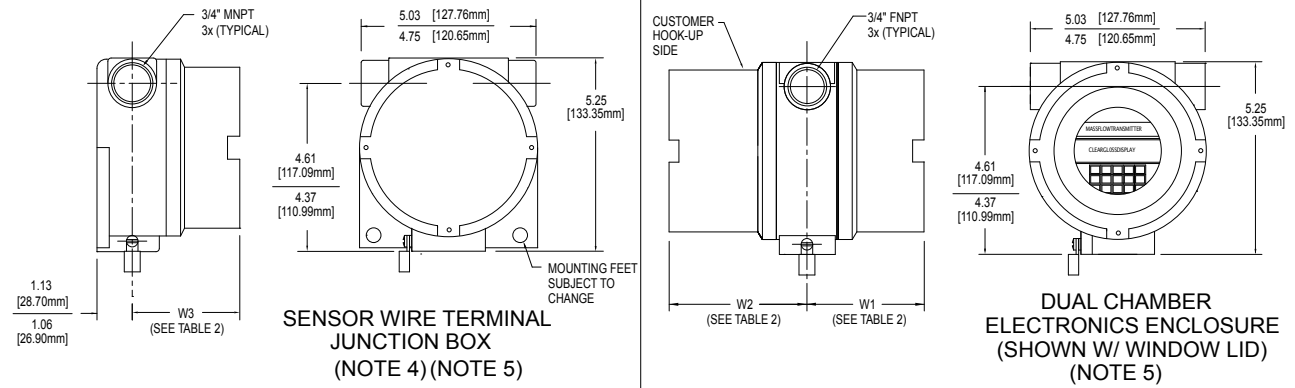

TABLE 1. PROBE DIAMETER DIMENSION

MODEL NO.	D
-12	0.75 [19.05mm]
-16	1.00 [25.4mm]

TABLE 2. ENCLOSURE DIMENSION (NOTE 5)

INPUT POWER	DISPLAY / KEYPAD	W1 (MAX.) (MIN.)	W2 (MAX.) (MIN.)	W3 (MAX.) (MIN.)
AC	YES	3.63 [92.20mm]	5.01 [127.25mm]	N/A
		3.41 [86.61mm]	4.69 [119.13mm]	
AC	NO	3.16 [80.26mm]	5.01 [127.25mm]	N/A
		2.81 [71.37mm]	4.69 [119.13mm]	
24VDC	YES	3.63 [92.20mm]	5.01 [127.25mm]	N/A
		3.41 [86.61mm]	4.69 [119.13mm]	
24VDC	NO (NOTE 4)	N/A	N/A	5.01 [127.25mm]
				4.88 [123.95mm]
SENSOR WIRE TERMINAL J-BOX (FOR REMOTE OPT.)		N/A	N/A	3.16 [80.26mm]
				2.81 [71.37mm]

NOTES:

- 1) FOR FLANGED OPTION: L = (U + L2 - 2.00 [50.8mm]), U (MIN.) = 4.00 [101.6mm].
- 2) L2 (MIN.) FOR -HT TO BE 5.00 [127mm].
- 3) THIS PROBE CONFIGURATION ALSO USED FOR DIRECTLY ATTACHED, DC POWERED, NO DISPLAY.
- 4) SENSOR WIRE TERMINAL JUNCTION BOX USED FOR SENSOR ELECTRONICS FOR DC POWERED, NO DISPLAY.
- 5) ENCLOSURE STYLES AND DIMENSIONS ARE SUBJECT TO CHANGE.
- 6) THIS CONFIGURATIONS ALLOWS FOR PROBE ASSY TO BE MOUNTED IN ZONE 1 AREA AND FOR REMOTE ELECTRONICS TO BE MOUNTED IN ZONE 2 AREA.



2411 Garden Road • Monterey, CA 93940 | 800-424-7356 • 831-646-5911 | www.KurzInstruments.com

756 4 1 0
Parent number

F1 F2 F3 F4 F5 F6 F7 F8 F9 F10 F11 F12 F13

Parent Number	Model
756410	454FTB-WGF

F1	Option	Probe Support Diameter
	B	0.75"(19 mm) (6" - 36" probe length)
	C	1"(25 mm) (6" - 60" probe length)

F2	Option	Probe Support & Flange Material
	2	316L stainless steel
	3	C-276 alloy

F3	Option	Probe Support Length
	B	6" (152 mm) (0.75" or 1" probe)
	C	9" (229 mm) (0.75" or 1" probe)
	D	12" (305 mm) (0.75" or 1" probe)
	F	18" (457 mm) (0.75" or 1" probe)
	H	24" (610 mm) (0.75" or 1" probe)
	J	30" (762 mm) (0.75" or 1" probe)
	K	36" (914 mm) (0.75" or 1" probe)
	M	48" (1219 mm) (1" probe)
	P	60" (1524 mm) (1" probe)

F4	Compression Fittings or Flanges
	Choose one only - None, Compression Fitting, or Flange

Option	Compression Fittings
1A	None
2B	0.75" MNPT (0.75" probe only), stainless steel front and back ferrules
2D	0.75" MNPT (0.75" probe only), PTFE-compound front and back ferrules
2G	1" MNPT (0.75" or 1" probe), stainless steel front and back ferrules
2J	1" MNPT (0.75" or 1" probe), PTFE-compound front and back ferrules

Option 1 Class 150 lbs.	Option 2 Class 300 lbs.	ANSI 16.5 Flange	0.75" and 1" probe diameter
1A	1A	None	
3D	4E	0.75" (19 mm)	1" probe diameter
3F	4G	1" (25 mm)	
3J	4K	1.5" (38 mm)	
3L	4M	2" (51 mm)	
3N	4P	2.5" (64 mm)	
3S	4T	3" (76 mm)	
3U	4V	4" (102 mm)	

F5	Option	Flange U Dimension
		Enter 000 for no flange connection. Enter U-dimension to nearest 10th of an inch without a decimal point. For example, 7.7" is 077 and 23.6" is 236. Note: Convert metric units to English units.

F6	Option	Electronics Configuration (ATEX Flameproof Pending)
	A	Integral — Standard Display viewing Aluminum Type 4, IP66 enclosure Explosion-Proof / Flame-Proof sensor: CSA, ATEX, and IECEx Exd IIB +H2Tx ; Exd IIB +H2Tx Gb; Class I Zone 1 AExd IIB +H2Tx Gb Sensing element, Tp: -40°C to 45°C; T4 or to 110°C; T3 DC power electronics housing, Ta: -40°C to 65°C; T4 AC power electronics housing, Ta: -40°C to 50°C; T4 or to 65°C; T150°C (T3) CSA Approved for Class I, Division 1, Groups B, C, D

	E	Integral — Display rotated 180° for viewing Aluminum Type 4, IP66 enclosure Explosion-Proof / Flame-Proof sensor: CSA, ATEX, and IECEx Exd IIB +H2Tx ; Exd IIB +H2Tx Gb; Class I Zone 1 AExd IIB +H2Tx Gb Sensing element, Tp: -40°C to 45°C; T4 or to 110°C; T3 DC power electronics housing, Ta: -40°C to 65°C; T4 AC power electronics housing, Ta: -40°C to 50°C; T4 or to 65°C; T150°C (T3) CSA Approved for Class I, Division 1, Groups B, C, D
--	---	--

	H	Remote — Transmitter and sensing element separate Sensor enclosure: Stainless Steel Type 4X, IP66 Electronics enclosure: Stainless Steel Type 4X, IP66 Explosion-Proof / Flame-Proof sensor: CSA, ATEX, and IECEx Exd IIB +H2Tx ; Exd IIB +H2Tx Gb; Class I Zone 1 AExd IIB +H2Tx Gb Sensing element, Tp: -40°C to 45°C; T4 or to 110°C; T3 DC power electronics housing, Ta: -40°C to 65°C; T4 AC power electronics housing, Ta: -40°C to 50°C; T4 or to 65°C; T150°C (T3) CSA Approved for Class I, Division 1, Groups B, C, D
--	---	--

	J	Remote — Transmitter and sensing element separate Aluminum Type 4, IP66 enclosures Explosion-Proof / Flame-Proof sensor: CSA, ATEX, and IECEx Exd IIB +H2Tx ; Exd IIB +H2Tx Gb; Class I Zone 1 AExd IIB +H2Tx Gb Sensing element, Tp: -40°C to 45°C; T4 or to 110°C; T3 DC power electronics housing, Ta: -40°C to 65°C; T4 AC power electronics housing, Ta: -40°C to 50°C; T4 or to 65°C; T150°C (T3) CSA Approved for Class I, Division 1, Groups B, C, D
--	---	---

	M	Remote — Transmitter and sensing element separate Sensor enclosure: Aluminum Type 4, IP66 Electronics enclosure: Polycarbonate Type 4, IP54 Explosion-Proof / Flame-Proof sensor: CSA, ATEX, and IECEx Non-Incendive electronics: CSA, ATEX Sensing element: Exd IIB +H2Tx; Exd IIB +H2Tx Gb; Class I Zone 1 AExd IIB +H2Tx Gb, Tp: -40°C to 45°C; T4 or to 110°C; T3 Electronics housing: ExnA IICTx; ExnA IICTxGc; Class I Zone 2 AExnA IICTxGc, Ta: -25°C to 50°C; T4 Sensing element: CSA Approved for Class I, Division 1, Groups B, C, D Electronics housing: CSA Approved for Class I, Division 2, Groups B, C, D
--	---	---

F7	Option	Display /Keypad
	1	Display /Keypad
	2	Blind

F8	Option	Power
	A	AC (85-265V 47/63Hz, 24 watts max)
	D	DC (24V ±10%), 1A max.

more on next page



F9	Option	Communications and Inputs/Outputs	
	2	Standard	Two 4-20mA isolated outputs
	3	Full	Two 4-20mA isolated outputs, two relays, two digital inputs, one non-isolated 4-20mA input
	5	HART-1	One 4-20mA isolated output, two relays, two digital inputs, one non-isolated 4-20mA input
	6	HART-2	Two 4-20mA isolated outputs, two relays, two digital inputs, one non-isolated 4-20mA input
	8	Profibus DP	Two 4-20mA isolated outputs, two relays, two digital inputs, one non-isolated 4-20mA input

F10	Option	Gas Type
	A	Air (laboratory calibration)
	D	Methane and Carbon Dioxide mix (correlation calibration)
	H	Variable CH ₄ composition for a CH ₄ /CO ₂ gas mix (correlation calibration)
	M	One correlation calibration curve (gas composition up to five gases)
	N	Two correlation calibration curves (gas composition up to five gases each)
	O	Three correlation calibration curves (gas composition up to five gases each)
	P	Four correlation calibration curves (gas composition up to five gases each)
	Q	Five correlation calibration curves (gas composition up to five gases each)

F11	Option	Percent of Methane
	—	Enter two digits for percent of methane. Enter two zeros (00) for Air only . Enter YY for all other gases.

F12	Option	Velocity Calibration Range	
	B	300 SFPM	(1.4 NMPS)
	C	600 SFPM	(2.8 NMPS)
	E	1,000 SFPM	(4.7 NMPS)
	G	2,000 SFPM	(9.3 NMPS)
	K	4,000 SFPM	(18.6 NMPS) *
	M	6,000 SFPM	(28 NMPS) * †
	P	9,000 SFPM	(41.9 NMPS) * †
	R	12,000 SFPM	(56 NMPS) * †
		* Reduced condensate immunity in Biogas † Reduced condensate immunity in Air	

F13	Option	Calibration Type
	1	Correlation
	2	Laboratory