

## Insertion Flow Meter Series 454FTB

The Kurz454FTB single-point insertion flow meter for industrial gas flow measurement includes the qualities and features found in all Kurz constant temperature thermal flow meters that make them outperform all other currently available thermal mass flow meters, including:

- The highest repeatability, accuracy, and reliability available
- The fastest response to temperature and velocity changes in the industry
- Constant temperature thermal technology
- Interchangeable sensor and electronics (single circuit board) — no matched sets
- Continuous self-monitoring electronics that verify the integrity of sensor wiring and measurements
- Sensor does not overheat at zero flow using a unique constant temperature control method and power limiting design
- Zero velocity as a valid data point
- Insensitive to left or right horizontal installations
- Completely field configurable using the local user interface or via a computer connection
- Supports HART, Profibus DP, and Modbus communication protocols
- User-programmable correction factors to compensate for velocity profiles
- User-defined binary gas compositions or up to five multiple gas calibrations
- Velocity-temperature mapping for wide ranging velocity and temperature
- Sensor Blockage Correction Factor (SBCF)
- Flexibility with transmitter-attached or transmitter-separate designs
- Patented digital sensor control circuit (US 7,418,878)

Kurz Instruments is dedicated to manufacturing and marketing the best thermal mass flow meters available and to support our customers in their efforts to improve their businesses.

### Applications

Primary, secondary, tertiary & overfire air  
Stack & flue gas  
Flare gas  
Boilers & recovery boilers  
Industrial and process gases  
Compressed air  
Coal pulverizer air  
Cement plants  
Aeration air and treated biogas  
EPA & AMS emissions monitoring



### Montar Messtechnik BV

Groendahlscher Weg 118  
D-46446 Emmerich am Rhein  
Tel. +49 (0) 2822 965425-0

sales@montar-mt.com

HRB nr. 70937338



## SPECIFICATIONS

- **Velocity range**  
0 to 70,000SFPM (325 NMPS)
- **Flow accuracy**(SCFM at laboratory conditions)  
±(1% of reading +20SFPM)
- **0.25% reading repeatability**
- **Velocity time constant**  
1 second for velocity changes at  
6,000SFPM (constant temperature)
- **Process temperature time constant**  
8 seconds for temperature changes at  
6,000SFPM (constant velocity)
- **Temperature accuracy**  
±(0.5% of reading +1°C) for  
velocities above 100SFPM
- **Electronics operating temperature**  
Integral display  
-13°F to 149°F (-25°C to 65°C)  
Remote aluminum enclosure  
-40°F to 149°F (-40°C to 65°C)  
Remote polycarbonate enclosure  
-13°F to 122°F (-25°C to 50°C)

## PROCESS CONDITIONS

- **Process pressure rating**  
Up to 300PSIG (20 BARg)
- **Process temperature rating**  
-40°F to 500°F (-40°C to 260°C) HT or  
-40°F to 932°F (-40°C to 500°C) HHT

## APPROVALS

- **EPA mandatory GHG certification**  
40 CFR 98.34(c)(1)
- **Alarm output conformity**  
NAMUR NE43
- **European Union CE compliance**  
EMC, LVD, PED, ROHS, and WEEE
- **Canadian Registration**  
CRN
- **CSA, ATEX & IECEx approvals for Nonincendive, Flameproof, and Explosion-proof**  
EN IEC 60079-0, EN IEC 60079-1  
EN IEC 60079-15, CSA Class I, Div. 1 and 2

## TRANSMITTER FEATURES

- **Aluminum (Type 4, IP66) dual chamber polyester powder-coated enclosure**
- **Adjustable display/keypad orientation**
- **Optically-isolated loop powered 4-20mA output** (±48VDC isolation)  
12-bit resolution and accuracy  
Maximum loop resistance is 300Ω at 18VDC,  
550Ω at 24VDC, 1400Ω at 36VDC
- **Input power**  
AC (85-264V 50/60 Hz, 24 watts max.)  
or DC (24V ±10%), 1A max.
- **Integral or remote user interface**
- **Easy-to-use interface**  
Backlit display / keypad  
2-lines of 16-characters each
- **User-configurable flow display (scrolling or static)**
- **User-configurable English or metric units for mass flow rate, mass velocity, and process temperature**  
oC, oF, KGH, KGM, NCMH, NLPM,  
NMPS, PPD, PPH, PPM, SCFH,  
SCFM, SCMH, SFPM, SLPM, SMPS
- **Velocity-dependent correction factors for flow rate**
- **Two optically isolated solid-state relays /alarms**  
Configurable as alarm outputs, pulsed totalizer output, or air purge cleaning
- **Built-in zero-mid-span drift check**
- **Built-in flow totalizers and elapsed time**
- **User-configurable digital filtering from 0 to 600 seconds**
- **Configuration/data access**  
USB or RS-485 Modbus (ASCII or RTU)
- **Meter memory**  
200 recent events, top 20 min/max, and  
56 hours (10 second samples of trends)
- **3-year warranty**

## SUPPORT & ELEMENT COMPONENTS

- **Sensor material**  
C-276 alloy all-welded sensor construction (standard)
- **Sensor support**  
316L stainless steel (standard)  
C-276 alloy (optional)  
PTFE coated (optional)
- **Sensor support diameter**  
1/2", 3/4", and 1"  
(12.7 mm, 19.05 mm, and 25.4 mm)
- **Sensor support length**  
6" to 60" (152 mm to 1524 mm)
- **3-year warranty**

## OPTIONS

- **Enclosures**  
Aluminum or polycarbonate (remote only)
- **Multiple gas calibrations with up to five curves loaded in memory**
- **User-defined binary gas compositions**
- **Communication protocols**  
HART (v7 FSK) and PROFIBUS DP
- **One 4-20mA non-isolated analog input**
- **Digital input dedicated to purge and zero-mid-span drift check**
- **Pulsed output as a remote flow totalizer**
- **Flow valve PID controller and configurable control application**  
Permits controlling set point velocity or flow rate through available control valve, damper, or 4-20mA interface
- **Hardware accessories**  
Available hardware includes flanges, ball valves, restraints, retractors, cable glands, conduit seals, cable, compression fittings, packing glands, and branch fittings





## PROCESS TEMPERATURE & COMPENSATION

Temperature influences the physical properties of gases, so temperature compensation is required for a thermal sensor to accurately measure gas flow rates.

- **Standard Temperature Compensation (STC)** is used for process temperatures from 0°C to 125°C or from 0°C to 260°C over a moderate velocity range.
- **Velocity Temperature Mapping (VTM)** is used when the process temperature and gas velocity vary widely. Multiple velocity calibrations are stored in the meter. VTM compensation is based on air; specific gas correlations are required to ensure accuracy at high temperatures.

## SPECIALTY GAS VELOCITY CALIBRATION

There are two types of gas calibration:

- **Laboratory gas calibrations** are performed with gases of high purity and are NIST traceable. Values above the calibrating facility limit are correlated up to the specified range. Customers must specify the calibration process pressure.
- **Correlation gas calibrations** are based on experimental data correlated to an Air calibration at ambient pressure and temperature. The flow element is calibrated in Air, and then an additional calibration data sheet is generated using the correlation factors. All correlation calibrations include velocity-temperature mapping.

Add  $\pm 5\%$  of reading to the accuracy specification when using a correlation calibration.

For Oxygen gas, the customer is responsible for ensuring the mass flow sensor is clean of hydrocarbons and safe for Oxygen use.

## ANALOG & DIGITAL INPUTS

All options include USB interface with ASCII text and Modbus protocol through RS-485.

The 4-20mA analog outputs (AO) are used for flow rate and/or temperature, or one AO for PID flow control. All AO are NAMUR NE-43 compliant.

Relay digital outputs (DO) can be alarms, EPA zero-mid-span drift is active, or pulsed totalizer function. PID uses one 4-20mA output for the flow controller. The EPA zero-mid-span drift check requires a contact closure to start the drift check. All 4-20mA outputs are used during the Drift Check Calibration process.

EPA zero-mid-span drift check can be initiated using digital inputs (DI), elapsed runtime automatic drift check, Modbus, or HART.

The 4-20mA analog input (AI) supports feedback to the device.

## AIR PURGE SENSOR CLEANING SYSTEM

The primary application for the Model 454PFTB is extremely dirty stacks and ducts having dry particulate matter that can build up on the sensors. Applications include fossil-fueled power boilers, municipal waste incinerators, and combustion air flow situations with entrained fly ash.

The Model 454PFTB is designed to measure air flow only at ambient pressure. Canadian Registration (CRN) is not available for the Model 454PFTB.

The Model 454PFTB has a special nozzle in the sensor window for use with the Model 146 Air Sensor Cleaning System. Sensor cleaning is accomplished by a short, high-pressure blast (sonic velocity) of air directed at the two sensors. The flow measurement value is held during the purge cycle.

The 454PFTB has a built-in timer and relay to initiate the purge cycle. Kurz provides solenoid valves and air blow-down tanks to allow periodic or on-demand cleaning. The air blow-down tank uses customer-supplied compressed air (instrument quality) at 60 to 125 PSIG. The average cleaning air consumption is less than 0.125 SCFM.



SERIES 454FTB OUTLINE DRAWINGS

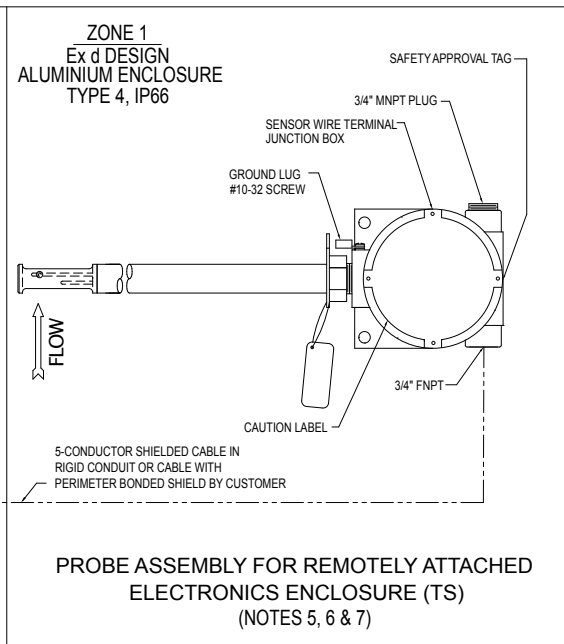
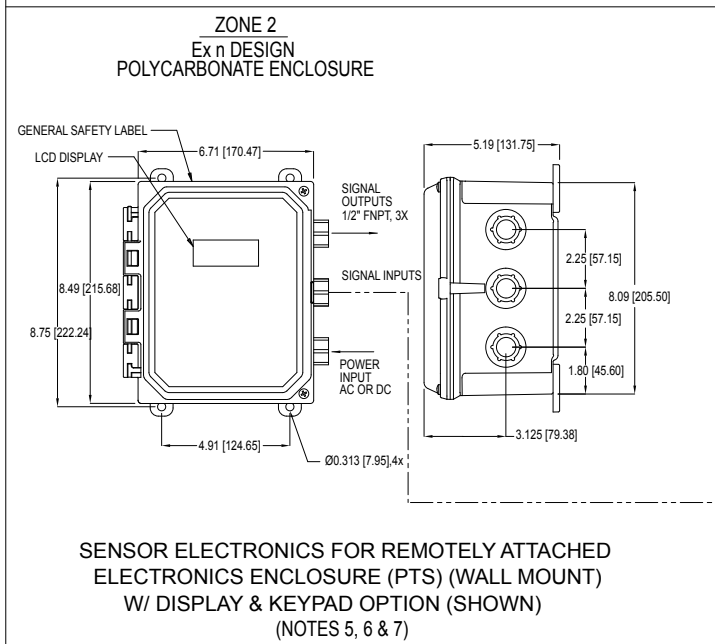
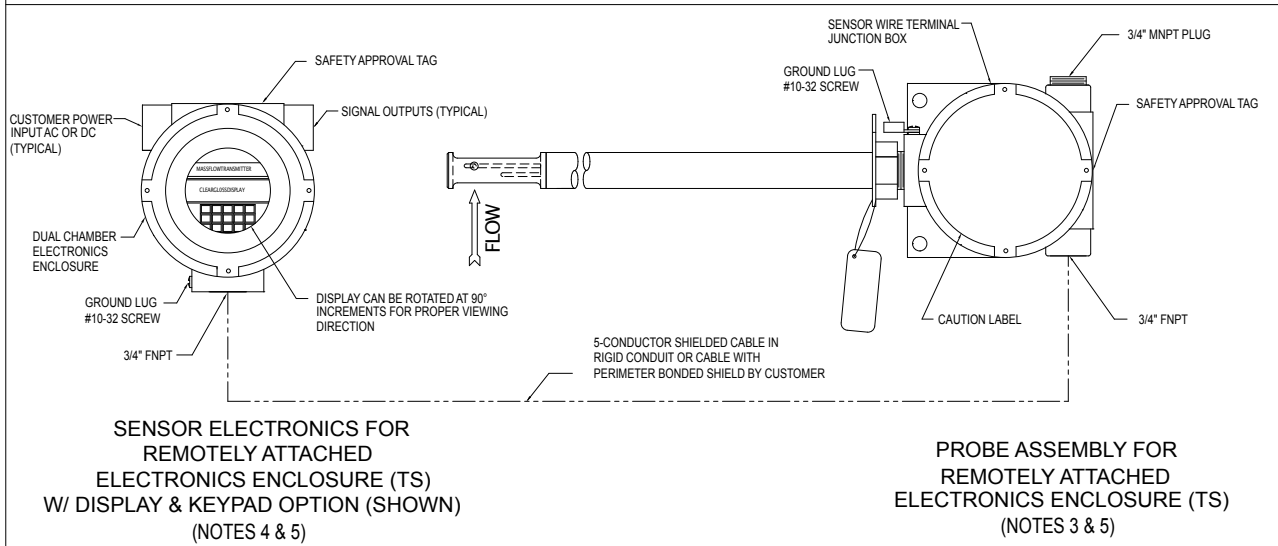
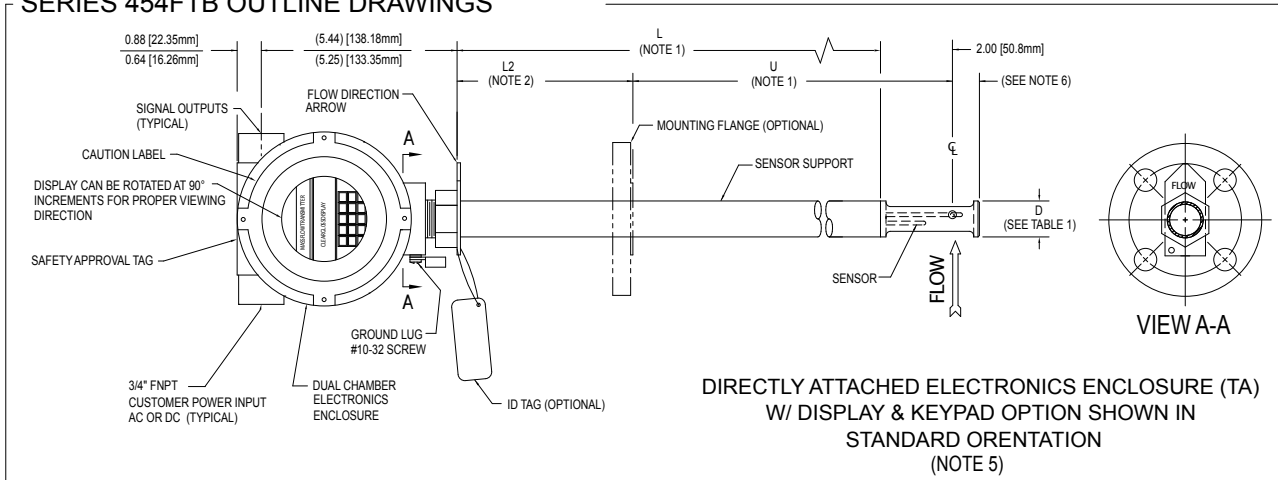



## SERIES 454FTB OUTLINE DRAWINGS (cont'd)

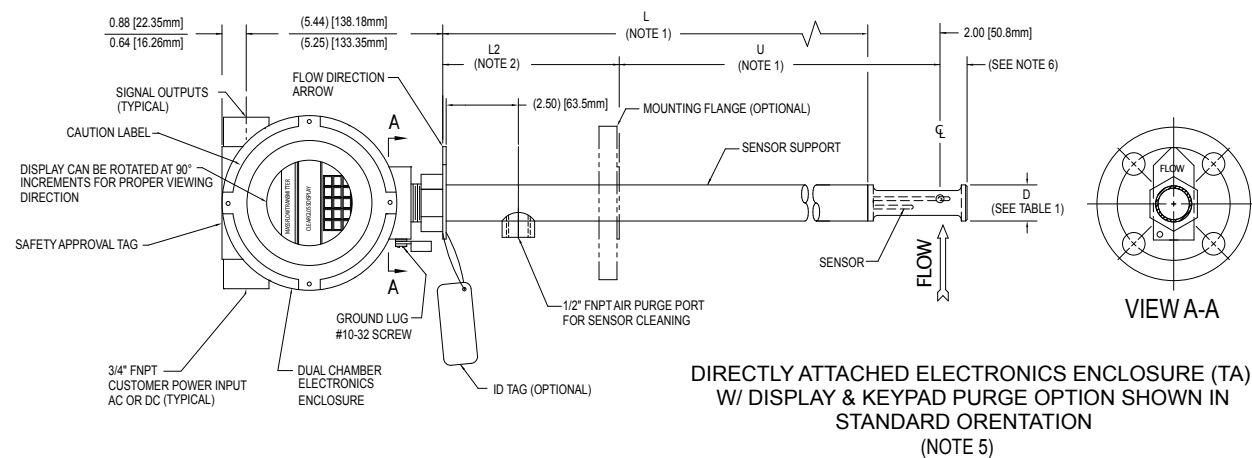
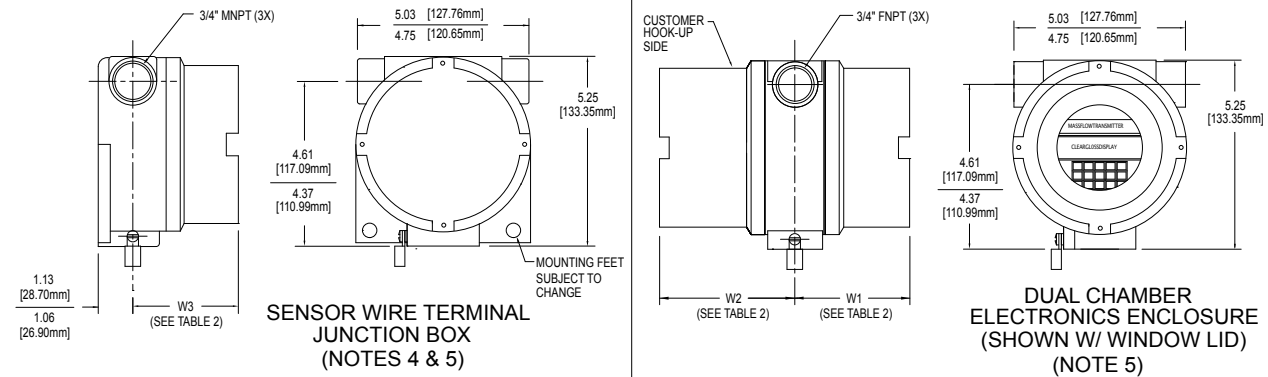

MODEL NO.	D
-12	0.50 [12.7mm]
-12	0.75 [19.05mm]
-16	1.00 [25.4mm]

INPUT POWER	DISPLAY / KEYPAD	W1 (MAX.) (MIN.)	W2 (MAX.) (MIN.)	W3 (MAX.) (MIN.)
AC	YES	3.63 [92.20mm]	5.01 [127.25mm]	N/A
		3.41 [86.61mm]	4.69 [119.13mm]	
AC	NO	3.16 [80.26mm]	5.01 [127.25mm]	N/A
		2.81 [71.37mm]	4.69 [119.13mm]	
24VDC	YES	3.63 [92.20mm]	5.01 [127.25mm]	N/A
		3.41 [86.61mm]	4.69 [119.13mm]	
24VDC	NO (NOTE 4)	N/A	N/A	5.01 [127.25mm]
				4.88 [123.95mm]
SENSOR WIRE TERMINAL J-BOX (FOR REMOTE OPT.)		N/A	N/A	3.16 [80.26mm]
				2.81 [71.37mm]

**NOTES:**

- 1) FOR FLANGED OPTION:  $L = (U + L2 - 2.00 [50.8mm])$ ,  $U (MIN.) = 4.00 [101.6mm]$
- 2) L2 (MIN.) FOR -HT TO BE 5.00 [127mm]  
L2 (MIN.) FOR -HHT TO BE 8.00 [203.2mm]
- 3) THIS PROBE CONFIGURATION ALSO USED FOR DIRECTLY ATTACHED, DC POWERED, WITHOUT DISPLAY.
- 4) SENSOR WIRE TERMINAL JUNCTION BOX USED FOR SENSOR ELECTRONICS FOR DC POWERED, WITHOUT DISPLAY.
- 5) ENCLOSURE STYLES AND DIMENSIONS ARE SUBJECT TO CHANGE.
- 6) DIM. FOR 454FTB-08 (.50 [12.7mm] DIA.) TO BE 0.78 [19.81mm]  
DIM. FOR 454FTB-12 (0.75 [19.05mm] DIA.) TO BE 0.78 [19.81mm]  
DIM. FOR 454FTB-16 (1.00 [25.4mm] DIA.) TO BE 0.78 [19.81mm]  
DIM. FOR 454PFTB-16 (1.00 [25.4mm] DIA.) TO BE 1.35 [34.29mm]
- 7) THIS CONFIGURATIONS ALLOWS FOR PROBE ASSY TO BE MOUNTED IN ZONE 1 AREA



2411 Garden Road • Monterey, CA 93940 | 800-424-7356 • 831-646-5911 | www.KurzInstruments.com

756

Parent number

F1

F2

F3

F4

F5

F6

F7

F8

F9

F10

F11

F12

Parent Number	Model	Support Diameter
756051	454FTB-08-HT	1/2"
756052	454FTB-08-HHT	1/2"
756053	454FTB-12-HT	3/4"
756054	454FTB-12-HHT	3/4"
756055	454FTB-16-HT	1"
756056	454FTB-16-HHT	1"
756057	454FTB-16-HT	1"

F1	Option	Electronics Enclosure Configuration and Input Power
	A	Directly attached dual-chamber electronics enclosure, AC/DC power, display / keypad
	B	Directly attached dual-chamber electronics enclosure, AC/DC power, without display / keypad
	C	Directly attached dual-chamber electronics enclosure rotated 180° for viewing, AC/DC power, display / keypad
	D	Remote dual-chamber electronics enclosure, AC/DC power, display / keypad
	E	Remote dual-chamber electronics enclosure, AC/DC power, without display / keypad
	F	Directly attached dual-chamber electronics enclosure, DC power, display / keypad
	G	Directly attached dual-chamber electronics enclosure rotated 180° for viewing, DC power, display / keypad
	H	Directly attached single-chamber electronics enclosure, DC power, without display / keypad
	I	Remote dual-chamber electronics enclosure, DC power, display / keypad
	J	Remote single-chamber electronics enclosure, DC power, without display / keypad
	R	Remote polycarbonate electronics enclosure, AC/DC power, with display / keypad
	S	Remote polycarbonate electronics enclosure, AC/DC power, without display / keypad
	T	Stainless steel sensor and electronics enclosures, AC power, with display / keypad
	V	Stainless steel sensor and electronics enclosures, AC power, without display / keypad
	W	Stainless steel sensor and electronics enclosures, DC power, with display / keypad
	X	Stainless steel sensor and electronics enclosures, DC power, without display / keypad

F2	Sensor & Probe Support / Flange Material	
	Choose one option from each category.	
	Option	Sensor Material (first digit)
	3	C-276 alloy
	7	C-276 alloy with abrasion-resistant aluminum titanium nitride (AlTiN) coating
	Option	Probe Support Material (second digit)
	2	316L stainless steel
	3	C-276 alloy
	8	C-276 alloy with PTFE coating cured for chemical resistance HHT models only, temperature maximum up to 260°C.

F3	Option	Probe Support Length	
	B	6" (152 mm)	(0.5", 0.75", or 1" probe)
	C	9" (229 mm)	(0.5", 0.75", or 1" probe)
	D	12" (305 mm)	(0.5", 0.75", or 1" probe)
	F	18" (457 mm)	(0.75" or 1" probe)
	H	24" (610 mm)	(0.75" or 1" probe)
	J	30" (762 mm)	(0.75" or 1" probe)
	K	36" (914 mm)	(0.75" or 1" probe)
	M	48" (1219 mm)	(1" probe)
	P	60" (1524 mm)	(1" probe)

F4	Option	Process Temperature Compensation
	1	Standard temperature compensation over process temperature range of -40°C to 125°C. Accuracy: $\pm(1 + 2000/V)\%$ , where V = SFPM, @ 25°C.
	2	Standard temperature compensation over process temperature range of 0°C to 260°C. Accuracy: $\pm(2 + 2000/V)\%$ , where V = SFPM, @ 125°C.
	3	Velocity-Temperature Mapping (VTM) with data sets over process temperature range of 0°C to 260°C. Accuracy: $\pm(2 + 2000/V)\%$ , where V = SFPM.
	4	Velocity-Temperature Mapping (VTM) with data sets over process temperature range of 0°C to 500°C. Accuracy: $\pm(3 + 3000/V)\%$ , where V = SFPM. Specify process temperature range. HHT models only.

F5	Option	Sensor Support Diameter & Flange Options	
	A	0.5", 0.75", 1"	No flange connection
	B	0.5"	0.5", Class 150, ANSI B16.5
	C	0.5"	0.5", Class 300, ANSI B16.5
	D	0.5", 0.75"	0.75", Class 150, ANSI B16.5
	E	0.5", 0.75"	0.75", Class 300, ANSI B16.5
	F	0.5", 0.75", 1"	1", Class 150, ANSI B16.5
	G	0.75", 1"	1", Class 300, ANSI B16.5
	H	0.75", 1"	1.25", Class 150, ANSI B16.5
	I	0.75", 1"	1.25", Class 300, ANSI B16.5
	J	0.75", 1"	1.5", Class 150, ANSI B16.5
	K	0.75", 1"	1.5", Class 300, ANSI B16.5
	L	0.75", 1"	2", Class 150, ANSI B16.5
	M	0.75", 1"	2", Class 300, ANSI B16.5
	N	1"	2.5", Class 150, ANSI B16.5
	P	1"	2.5", Class 300, ANSI B16.5
	S	1"	3", Class 150, ANSI B16.5
	T	1"	3", Class 300, ANSI B16.5
	U	1"	4", Class 150, ANSI B16.5
	V	1"	4", Class 300, ANSI B16.5

F6	Option	Flange U Dimension
		Enter 000 for no flange connection. Enter U-dimension to nearest 10th of an inch without a decimal point. For example, 7.7" is 077 and 23.6" is 236. <b>Note:</b> Convert metric units to English units.

more on next page





F7	Option	Velocity Calibration Range (Maximum)	
	A	Vmax	
	B	300SFPM	(1.4 NMPS)
	C	600SFPM	(2.8 NMPS)
	E	1,000SFPM	(4.7 NMPS)
	G	2,000SFPM	(9.3 NMPS)
	I	3,000SFPM	(14 NMPS)
	K	4,000SFPM	(18.6 NMPS)
	M	6,000SFPM	(28 NMPS)
	P	9,000SFPM	(41.9 NMPS)
	R	12,000SFPM	(56 NMPS)
	T	15,000SFPM	(70 NMPS)
	V	18,000SFPM	(84 NMPS)
	X	24,000SFPM	(112 NMPS)

### F8 Specialty Gas Velocity Calibration

	Laboratory Calibration	Correlation Calibration	Description
	01	-	Ambient Air
	07	-	Compressed Air
	-	0M	Compressed Air (correlated to 70,000SFPM)
	-	56	Dry Ammonia
	08	58	Argon
	-	60	Butane
	14	64	Carbon Dioxide
	-	68	Dry Chlorine
	20	70	Ethane
	22	72	Ethylene
	26	76	Helium
	28	-	Hydrogen
	32	82	Methane
	35	85	Digester Gas 50% CH <sub>4</sub> 50% CO <sub>2</sub>
	36	86	Digester Gas 60% CH <sub>4</sub> 40% CO <sub>2</sub>
	37	87	Digester Gas 70% CH <sub>4</sub> 30% CO <sub>2</sub>
	-	8K	User-Defined Binary Gas Composition
	-	8M	One Gas Curve
	-	8N	Two Gas Curves
	-	8O	Three Gas Curves
	-	8P	Four Gas Curves
	-	8Q	Five Gas Curves
	40	90	Nitrogen
	44	94	Oxygen
	46	96	Propane

**Notes:** Laboratory gas calibrations are performed with high purity gases and are NIST traceable. Customers must specify process pressure (Feature 10). Propane to 50PSIA, all other gases to 150PSIA. Options 8M-8Q allow up to a 5-gas mixer curve; contact KurzSalesSupport if Hydrogen is included in the mix.

### F9 Option Safety Approvals

F9	Option	Safety Approvals
	A	<p>Non-Incendive, CSA, ATEX, and IECEx  <b>Aluminum enclosure Type 4, IP66</b>                      ExnA IICTx; ExnA IICTxGc; Class I Zone 2 AExnA IICTxGc                      Sensing element, T<sub>p</sub>: -40°C to 55°C; T<sub>5</sub> or to 130°C; T<sub>3</sub>                      DC power electronics housing, T<sub>a</sub>: -40°C to 65°C; T<sub>4</sub>                      AC power electronics housing, T<sub>a</sub>: -40°C to 50°C; T<sub>4</sub> or to 65°C; T<sub>150</sub>°C</p> <p>CSA Approved for Class I, Division 2, Groups B, C, D</p>
	B	<p><b>Explosion-Proof/Flame-Proof, CSA, ATEX, and IECEx</b>  <b>Aluminum enclosure Type 4, IP66</b>                      Exd IIB +H<sub>2</sub>Tx; Exd IIB +H<sub>2</sub>Tx Gb; Class I Zone 1 AExd IIB +H<sub>2</sub>Tx Gb                      Sensing element, T<sub>p</sub>: -40°C to 45°C; T<sub>4</sub> or to 110°C; T<sub>3</sub>                      DC power electronics housing, T<sub>a</sub>: -40°C to 65°C; T<sub>4</sub>                      AC power electronics housing, T<sub>a</sub>: -40°C to 50°C; T<sub>4</sub> or to 65°C; T<sub>150</sub>°C (T<sub>3</sub>)</p> <p>CSA Approved for Class I, Division 1, Groups B, C, D</p>
	D	<p><b>Transmitter and sensing element separate</b>  <b>Sensor enclosure: Aluminum Type 4, IP66</b>  <b>Electronics enclosure: Polycarbonate Type 4, IP54</b>                      (Feature 1, Option R or S)                      Sensing element:                      Exd IIB +H<sub>2</sub>Tx; Exd IIB +H<sub>2</sub>Tx Gb; Class I Zone 1 AExd IIB +H<sub>2</sub>Tx Gb,                      T<sub>p</sub>: -40°C to 45°C; T<sub>4</sub> or to 110°C; T<sub>3</sub>                      Electronics housing:                      ExnA IICTx; ExnA IICTxGc; Class I Zone 2 AExnA IICTxGc; T<sub>a</sub>: -25°C to 50°C; T<sub>4</sub></p> <p>Sensing element:                      CSA Approved for Class I, Division 1, Groups B, C, D                      Electronics housing:                      CSA Approved for Class I, Division 2, Groups B, C, D</p>
	H	<p><b>Remote — Transmitter and sensing element separate</b>  <b>Sensor enclosure: Stainless Steel Type 4X, IP66</b>  <b>Electronics enclosure: Stainless Steel Type 4X, IP66</b>                      Explosion-Proof /Flame-Proof sensor: CSA, ATEX, and IECEx                      Exd IIB +H<sub>2</sub>Tx; Exd IIB +H<sub>2</sub>Tx Gb; Class I Zone 1 AExd IIB +H<sub>2</sub>Tx Gb                      Sensing element, T<sub>p</sub>: -40°C to 45°C; T<sub>4</sub> or to 110°C; T<sub>3</sub>                      DC power electronics housing, T<sub>a</sub>: -40°C to 65°C; T<sub>4</sub>                      AC power electronics housing, T<sub>a</sub>: -40°C to 50°C; T<sub>4</sub> or to 65°C; T<sub>150</sub>°C (T<sub>3</sub>)</p> <p>CSA Approved for Class I, Division 1, Groups B, C, D</p>

### F10 Option Process Pressure

Enter the Absolute Pressure (PSIA) rounded to 3 digits. For example, a process Absolute Pressure of 14.7 PSIA, round to 15.0 and enter 015; for 150 PSIA enter 150.

### F11 Option Communications and Inputs/Outputs

F11	Option	Communications and Inputs/Outputs
	B	Standard Two 4-20mA isolated outputs
	C	Full Two 4-20mA isolated outputs, two relays, two digital inputs, one non-isolated 4-20mA input
	E	HART-1 One 4-20mA isolated output, two relays, two digital inputs, one non-isolated 4-20mA input
	H	HART-2 Two 4-20mA isolated outputs, two relays, two digital inputs, one non-isolated 4-20mA input
	K	Profibus DP Two 4-20mA isolated outputs, two relays, two digital inputs, one non-isolated 4-20mA input

### F12 Option Process Temperature

Enter the Absolute Temperature (°Rankin = °F + 460) rounded to 3 digits. For example, a Process Temperature of 77°F is written as 537 (77 + 460).