

## Multipoint Insertion Flow Meter Series K-BAR2000B

The KurzK-BAR2000B multipoint insertion flow meter for combustion control and emissions monitoring includes the qualities and features found in all Kurz constant temperature thermal flow meters that make them outperform all other currently available thermal mass flow meters, including:

- Ideal for large stacks and ducts with non-uniform velocity profiles
- The highest repeatability, accuracy, and reliability available
- The fastest response to temperature and velocity changes in the industry
- Capable of reading low flows that occur during start-up, shut-down, or obstruction events
- Easy installation and no maintenance
- Sensors are resistant to dirt and corrosion
- Individual sensor optimization for flow profile variations
- Interchangeable sensor and electronics — no matched sets
- Continuous self-monitoring electronics that verify the integrity of sensor wiring and measurements
- Constant temperature thermal technology
- Sensors do not overheat at zero flow by using a unique constant temperature control method and power limiting design
- Zero velocity as a valid data point
- Completely field configurable using the local user interface or via a computer connection
- User-programmable dual gas mix interpolation
- User-programmable correction factors to compensate for velocity-dependent profile shifts
- Velocity-temperature mapping for wide ranging velocity and temperature
- Supports HART, Profibus DP, and Modbus communication protocols
- Patented digital sensor control circuit (US 7,418,878)

Kurz Instruments is dedicated to manufacturing and marketing the best thermal mass flow meters available and to support our customers in their efforts to improve their businesses.

### Applications

- Primary, secondary, tertiary & overfire air
- Stack & flue gas
- Flare gas
- Boilers & recovery boilers
- Coal pulverizer air
- EPA & AMS emissions monitoring

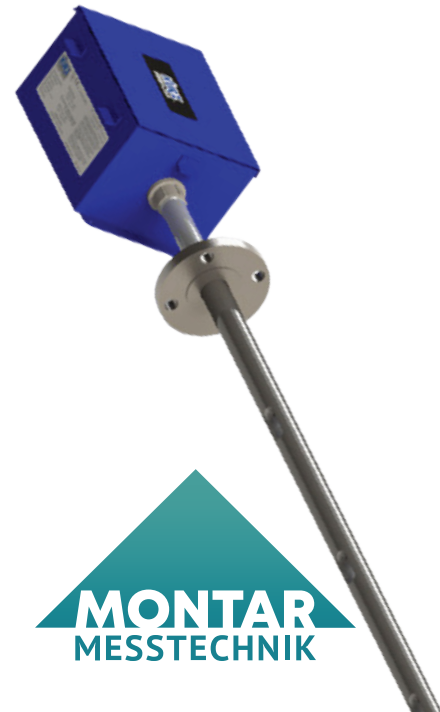

### Montar Messtechnik BV

Groendahlscher Weg 118  
D-46446 Emmerich am Rhein  
Tel. +49 (0) 2822 965425-0

sales@montar-mt.com

HRB nr. 70937338



## SPECIFICATIONS

- **Velocity range**  
0 to 12,000SFPM (56 NMPS)
- **Velocity accuracy**  
±(1% of reading +20SFPM)
- **0.25% reading repeatability**
- **Velocity time constant**  
1 second for velocity changes at 6,000SFPM (constant temp)
- **Process temperature time constant**  
8 seconds for temp changes at 6,000SFPM (constant velocity)
- **Velocity angle sensitivity**  
<2% per degree angle up to ±20°
- **Velocity-dependent correction factors for flow rate**
- **Electronics operating temperature**  
-40°F to 149°F (-40°C to 65°C)

## PROCESS CONDITIONS

- **Process pressure rating**  
Up to 150 PSIG (10 BARg)
- **Process temperature rating**  
-40°F to 500°F (-40°C to 260°C) (HT)  
-40°F to 932°F (-40°C to 500°C) (HHT)

## APPROVALS

- **EPA mandatory GHG certification**  
40 CFR 98.34(c)(1)
- **Alarm output conformity**  
NAMUR NE43
- **European Union CE compliance**  
EMC, LVD, PED, QAL1 (as part of a complete KurzAMS solution), ROHS, and WEEE
- **EU ATEX, Increased Safety**  
EN 60079-0:2018 & EN 60079-7:2015/A1:2018  
II 3 G, Ex ec IIC T5...T3 Gc  
Flow Element T<sub>p</sub>:  
-40 to 55 °C: T5 or to 130 °C: T3  
Flow Transmitter T<sub>a</sub>:  
-40 to 50 °C: T6 or to 65 °C: T5

## TRANSMITTER FEATURES

- **Steel, 16 gauge (Type 4, IP65) polyester powder-coated enclosure**
- **Two optically-isolated loop powered 4-20mA outputs**  
12-bit resolution and accuracy  
Maximum loop resistance is 300Ω at 18 VDC, 550Ω at 24 VDC, 1400Ω at 36 VDC
- **One 4-20mA non-isolated analog input**
- **Input power**  
1 Amp per sensor, DC (21.6-26.4V)
- **Two optically isolated solid-state relays /alarms**  
Configurable as alarm outputs, pulsed totalizer output, or air purge cleaning
- **Two digital inputs dedicated to purge and zero-mid-spandrift check**
- **Velocity-dependent correction factors for flow rate**
- **Built-in zero-mid-spandrift check**
- **Built-in flow totalizers and elapsed time**
- **User-configurable digital filtering from 0 to 600 seconds**
- **Configuration/data access**  
USB or RS-485 Modbus (ASCII or RTU)
- **Meter memory**  
200 recent events, top 20 min/max, and 56 hours (10 second samples) of trends
- **3-year warranty**

## SUPPORT & ELEMENT COMPONENTS

- **Sensor material**  
C-276 alloy all-welded sensor construction (standard)
- **Sensor support**  
316L stainless steel (standard)  
Hastelloy® C-22 alloy (optional)
- **Sensor support diameter**  
Segment 1 - 1½" tubing (standard)  
Segment 2 - 2½" (Sch.10)  
Segment 3 - 4" (Sch 10)
- **Sensor support length**  
Maximum length based on supported or self-supporting design and the number of sensors
- **Mounting flange**  
Raised face Class 150 ANSI B16.5
- **3-year warranty**

## OPTIONS

- **Communication protocols**  
HART (v7 FSK) and PROFIBUS DP
- **Hardware accessories**  
Available hardware includes flange mounting assemblies, ball valves, conduit seals, cable, and packing glands
- **SIL1 certification**  
via TÜV Rheinland





## K-BAR DESIGN

All K-BARs include the flange-to-inside-wall (FTIW) measurement when determining the length of the probe support.

The K-BAR can be a supported or self-supporting structure.

- A supported K-BAR has an external or internal support cup on the wall opposite the mounting flange. A supported K-BAR allows for a smaller flange and a consistent 1.5" probe support across the width of the stack/duct. A supported probe support with 2, 3, or 4 sensors can be up to 173" (including the FTIW distance).

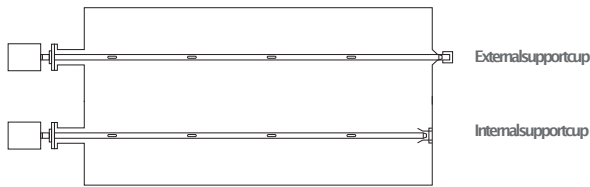

- A self-supporting K-BAR, depending on the length, can have up to three support probe sections that reduce in diameter toward the probe support tip. In addition, the number of sensors is a factor in determining the maximum probe support length.

- One segment = 1.5", stack/duct up to 302 inches
- Two segments = 2.875", 1.5", stack/duct up to 488 inches
- Three segments = 4.5", 2.875", 1.5", stack/duct up to 460 inches

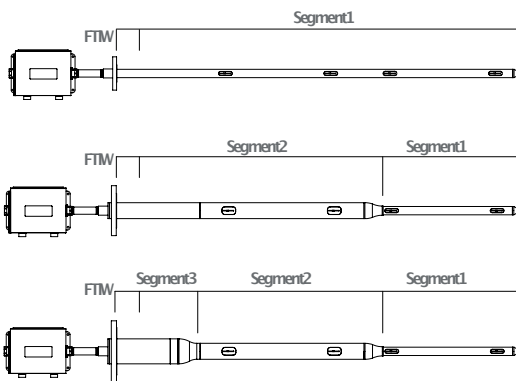

**Note:** The additional material used to increase the diameter of segments 2 and 3 also slows the effects of corrosion on the probe support.

## HALF SPAN AND FULL SPAN

Using a supported or self-supporting K-BAR is determined by several factors:

- The dimensions of the stack or duct
- The accessibility of an installation location
- The flow profile of the stack or duct
- Excessive vibration

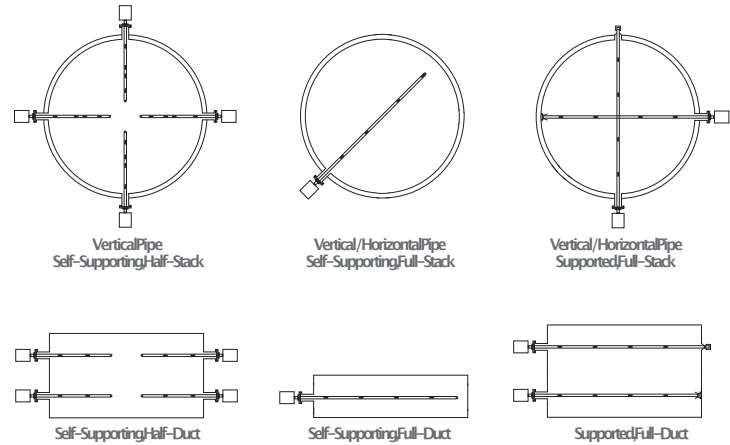



Typical Installation Setup

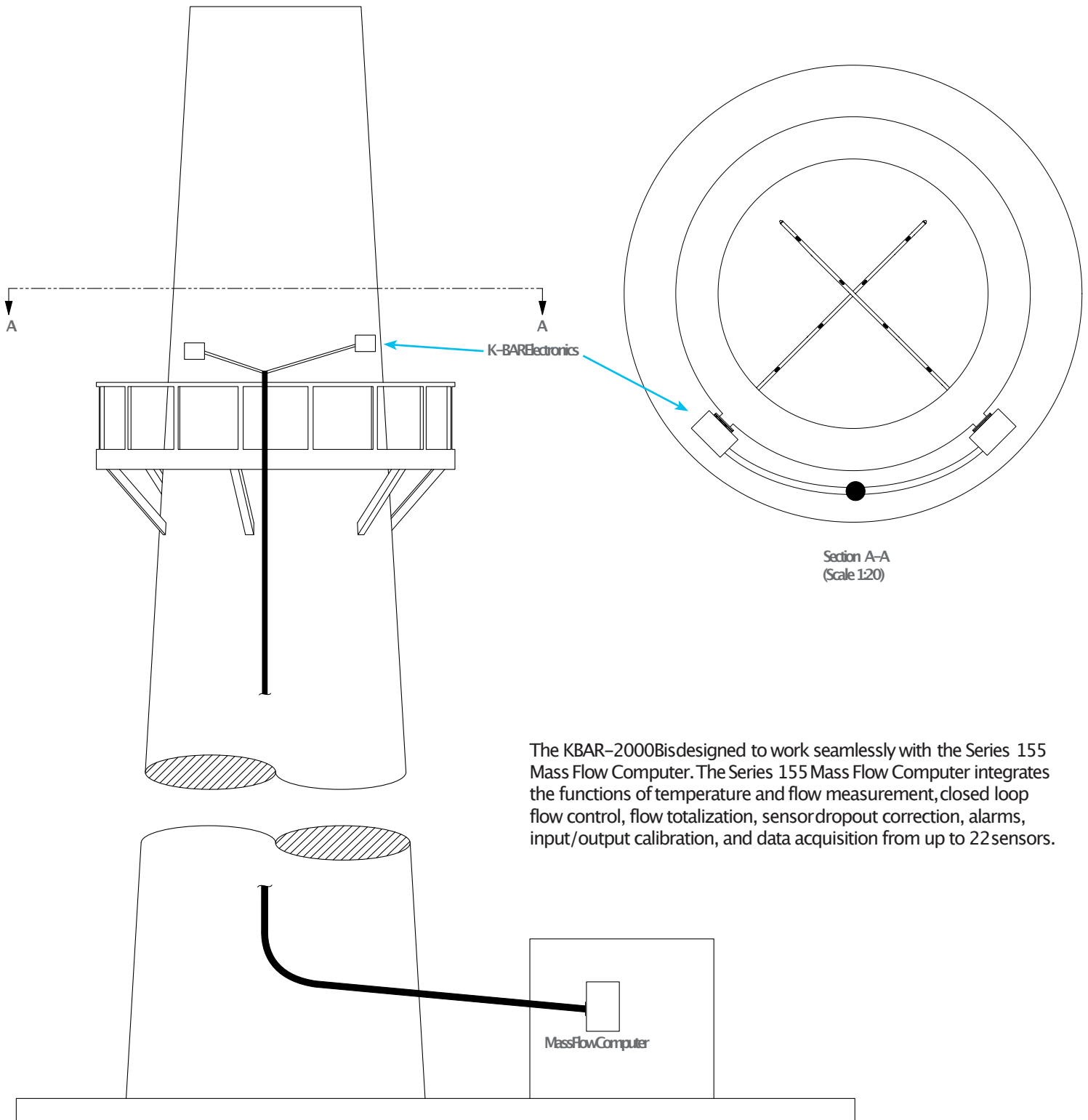

The K-BAR-2000B is designed to work seamlessly with the Series 155 Mass Flow Computer. The Series 155 Mass Flow Computer integrates the functions of temperature and flow measurement, closed loop flow control, flow totalization, sensor dropout correction, alarms, input/output calibration, and data acquisition from up to 22 sensors.



2411 Garden Road • Monterey, CA 93940 | 800-424-7356 • 831-646-5911 | www.KurzInstruments.com

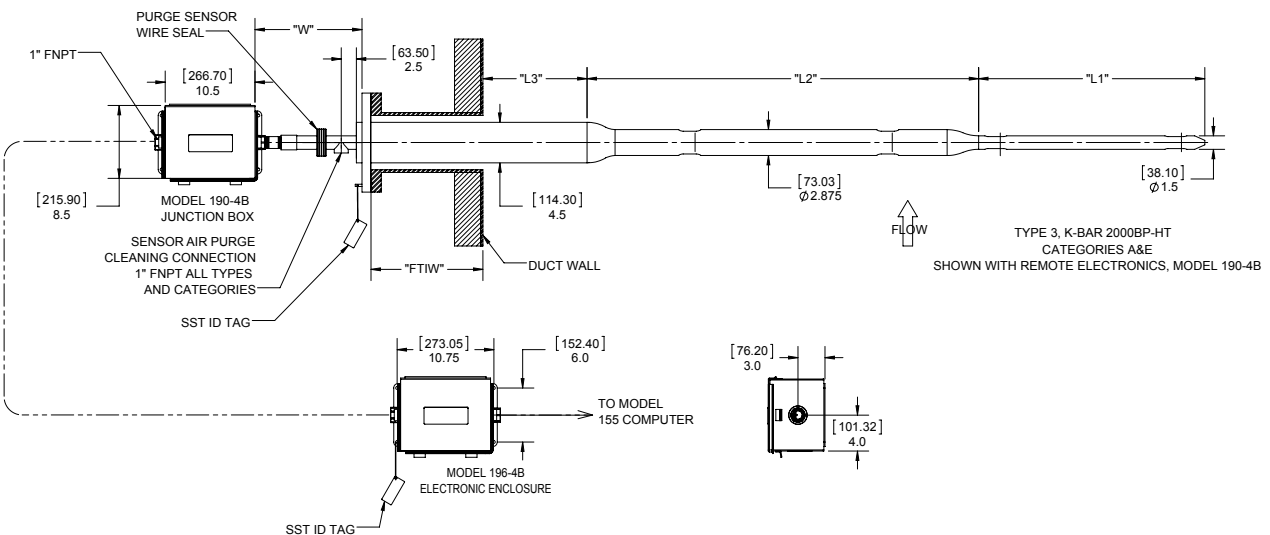
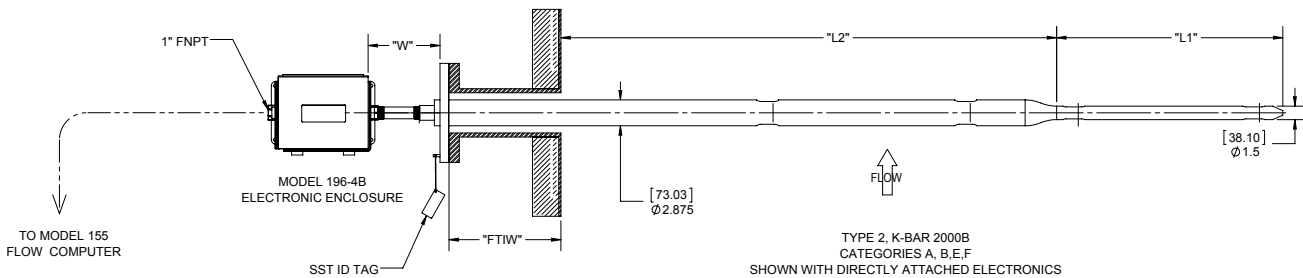
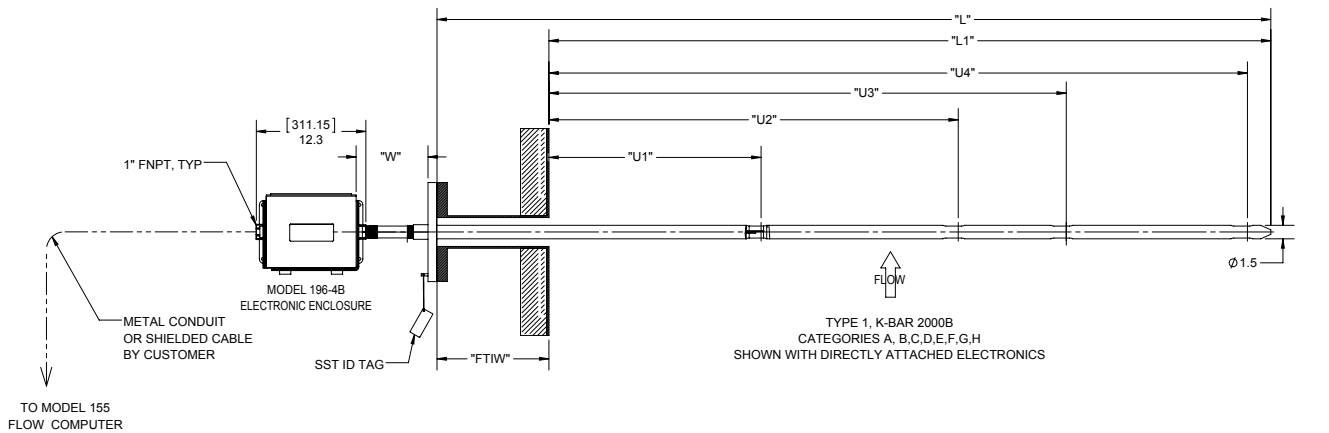

Identifier	Description
D	The round stack/duct diameter or rectangular stack/duct flow inside dimension (inches).
FTIW	The flange-to-insidewall measurement for determining the overall length of the probe support includes gaskets, flanges, and stack/duct wall thickness.

**Dimensions** All dimensions are in inches with millimeters in brackets.

Identifier	Description
L <sub>1</sub>	Length of segment #1 (inches).
L <sub>2</sub>	Length of segment #2 (inches).
L <sub>3</sub>	Length of segment #3 (inches).
L	Total length (inches) of K-BAR probe support (L <sub>1</sub> + L <sub>2</sub> + L <sub>3</sub> + FTIW).
U <sub>1</sub>	Location of first sensor from inside wall of stack/duct.
U <sub>2</sub>	Location of second sensor from inside wall of stack/duct.
U <sub>3</sub>	Location of third sensor from inside wall of stack/duct.
U <sub>4</sub>	Location of fourth sensor from inside wall of stack/duct.
W	HT=7.5", HHT=13.5", PB-HT (purge)=12"



753 \_ \_ \_  
Parent number

F1

F2

F3

F4

F5

F6

F7

F8

F9

F10

F11

F12

Parent Number	Model
753731	K-BAR 2000B-HT (-40oF to 500oF / -40oC to 260oC)
753732	K-BAR 2000B-HHT (-40oF to 932oF / -40oC to 500oC)
753733	K-BAR2000PB-HT with Purge feature (Type 1 only)

F1	Option	K-BAR Installation Configuration Category
	A	Category A, round stack/duct, half span, single-end support, Type 1, 2, 3
	B	Category B, round stack/duct, full span, single-end support, Type 1, 2
	C	Category C, round stack/duct, full span, external end support, Type 1
	D	Category D, round stack/duct, full span, internal end support, Type 1
	E	Category E, rectangular stack/duct, half span, single-end support, Type 1, 2, 3
	F	Category F, rectangular stack/duct, full span, single-end support, Type 1, 2
	G	Category G, rectangular stack/duct, full span, external end support, Type 1
	H	Category H, rectangular stack/duct, full span, internal end support, Type 1

F2	Option	Stack/Duct Flow Dimensions (D)
		For round stacks/ducts, enter the inside diameter to the nearest tenth inch. For rectangular stacks/ducts, enter the inside diameter measured along the axis where the K-BAR will be installed to the nearest tenth inch. <b>Enter 4 digits.</b> For example, a round stack with 336 inch inside diameter is written as 3360.

F3	Option	Sensor Electronics Enclosure Configuration
	A	Directly attached electronics enclosure for up to four sensors. Model 196-4B only. NEMA 4 polyester powder-coated steel enclosure with 1" FNPT conduit hubs. Includes one stainless steel ID tag.
	B	Remote electronics enclosure. Model 196-4B electronics enclosure and Model 190-4B sensor wire junction box for up to four sensors. NEMA 4 polyester powder-coated steel enclosures with 1" FNPT conduit hubs. Includes two stainless steel ID tags.

F4	Option	K-BAR Construction Type
	1	One segment K-BAR and FTIW segment. All categories.
	2	Two segment K-BAR and FTIW segment. Category A, B, E, F.
	3	Three segment K-BAR and FTIW segment. Category A, E.

F5	Option	Communications and Inputs/Outputs
	C	Full Two 4-20mA isolated outputs, two relays, two digital inputs, one non-isolated 4-20mA input
	E	HART-1 One 4-20mA isolated output, two relays, two digital inputs, one non-isolated 4-20mA input
	H	HART-2 Two 4-20mA isolated outputs, two relays, two digital inputs, one non-isolated 4-20mA input
	K	Profibus DP Two 4-20mA isolated outputs, two relays, two digital inputs, one non-isolated 4-20mA input

F6	Option	Flange-To-Inside Wall Length (FTIW)
		Enter the length from the mating surface of the K-BAR mounting flange to the inside wall of the stack/duct to the nearest tenth inch. This measurement includes the gasket thickness and stack/duct wall thickness. <b>Enter 3 digits.</b> For example, the distance between the stack mounting flange and inside wall of the stack/duct (including gasket and wall thickness) is 56.25 inches and written as 563.

F7	Option	Process Temperature Compensation
	A	Standard temperature compensation (STC) over process temperature range from -40°C to 125°C. Accuracy: ±( 1% Reading + 20 SFPM) ±25°C.
	B	Standard temperature compensation (STC) over process temperature range from 0°C to 260°C. Accuracy: ±( 1% Reading + 20 SFPM) ±25°C.
	C	Velocity temperature mapping (VTM) with data over process temperature range from 0°C to 260°C. Accuracy: ±( 1% Reading + 20 SFPM) ±25°C.
	D	Velocity temperature mapping (VTM) with data over process temperature range from 0°C to 500°C. Accuracy: ±( 1% Reading + 20 SFPM) ±25°C.

F8	Sensors & Sensor Material
	Choose one option from each category.

Option	Number of Sensors (first digit)
2	Two
3	Three
4	Four

Option	Sensor Material (second digit)
3	C-276 alloy
7	C-276 alloy with abrasion-resistant aluminum titanium nitride (AlTiN) coating



F9	Option	Mounting Flange Size (CL150) & Thickness		
	H	1.5"	(Type 1)	0.69"
	J	2"	(Type 1)	0.75"
	L	2.5"	(Type 1, 2)	0.88"
	N	3"	(Type 1, 2)	0.94"
	Q	3.5"	(Type 1, 2)	0.94"
	S	4"	(Type 1, 2)	0.94"
	U	6"	(Type 1, 2, 3)	1.0"

F10	Option	Mounting Flange Material
	2	316L stainless steel
	3	C-276 alloy

F11	Option	Laboratory Air Velocity Calibration	
	A	300SFPM	(1.4 NMPS)
	C	600SFPM	(2.8 NMPS)
	E	1,000SFPM	(4.7 NMPS)
	G	2,000SFPM	(9.3 NMPS)
	I	3,000SFPM	(14 NMPS)
	K	4,000SFPM	(18.6 NMPS)
	M	6,000SFPM	(28 NMPS)
	P	9,000SFPM	(41.9 NMPS)
	R	12,000SFPM	(56 NMPS)

**F12 Segment Material**

Choose one option from each category.

Option	Segment #1 Material (first digit)		
2	316LSS tube / 316L SS windows	(Type 1, 2, 3)	
3	C-22alloy tube / C-276alloy windows	(Type 1)	
6	C-22alloy tube / 316L SS windows	(Type 1)	

Option	Segment #2 Material (second digit)		
0	No segment 2	(Type 1)	
2	316LSS pipe / 316L SS windows	(Type 2, 3)	

Option	Segment #3 Material (third digit)		
0	No segment 3	(Type 1, 2)	
2	316LSS pipe	(Type 3)	

Option	FTIW Segment Material (fourth digit)		
2	316LSS pipe	(Type 1, 2, 3)	
3	C-22alloy tube / C-276alloy pipe	(Type 1) / (Type 2, 3)	

**Notes:** Available configurations are 2002, 3003, 6003, 2202, 2203, 2222, and 2223.

Add the letter "S" to the end of Feature 12 to include SIL1 certification via TUV Rheinland.

