

A Higher Level of Performance



Data Sheet

G1

Microwave Switch Series

Beam Blockage Detection
Circular Polarisation



For more information, please visit >
www.hawkmeasure.com

Overview

G1 Microwave Switch Series



Principle of Operation

A high power circular polarized Microwave pulse is emitted from the Sending unit to the Receiving unit in a transmission chain of approximately 100 pulses per second. If the path between the Sender and Receiver is blocked by any object or material which absorbs or reflects microwave energy the Receiving unit will no longer detect the complete transmission chain and indicate via Relay for automatic indication and process control requirements.

Typical Uses

- Blocked chute detection
- Nucleonic switch replacement
- High level alarm / Low level alarm
- Truck / machine detection.

Function

The Gladiator Microwave Switch can be used for blockage detection, barrier detection, machine detection and point level measurement, and detection of objects or material between two points.

Primary Areas of Application

- Asphalt
- Brewing
- Cement
- Chemical
- Dairy
- Edible oil
- Fertilizer
- Food & Beverage
- Glass
- Mining & Metals
- Oil & Gas
- Packaging
- Paint
- Paper
- Pharmaceutical
- Plastics
- Power Generation
- Refining
- Semiconductor
- Sugar
- Textile
- Water & Wastewater.

Features

- State of the art circular polarisation
- Simple sensitivity adjustment and calibration
- IECEx ta tb IIIC T* Da Db
- Theoretical range up to 300m (984ft)
- Simple '1-minute' setup application presets
- Multiple Output & Communications Options
- Remote test function
- Adjustable ON and OFF delays (0-20 sec)
- Remote 3G Hawklink connection option
- Bright visual status indication on sensors
- Independent housing alignment after mounting sensor.

***Consult Safety Instructions**

Linear vs Circular Polarisation

G1 Microwave Switch Series



Previous Gladiator Microwave - Linear Polarisation

- Maximum Receiver Gain: 5000
- Maximum Distance : 100m
- Beam Angle: 40°

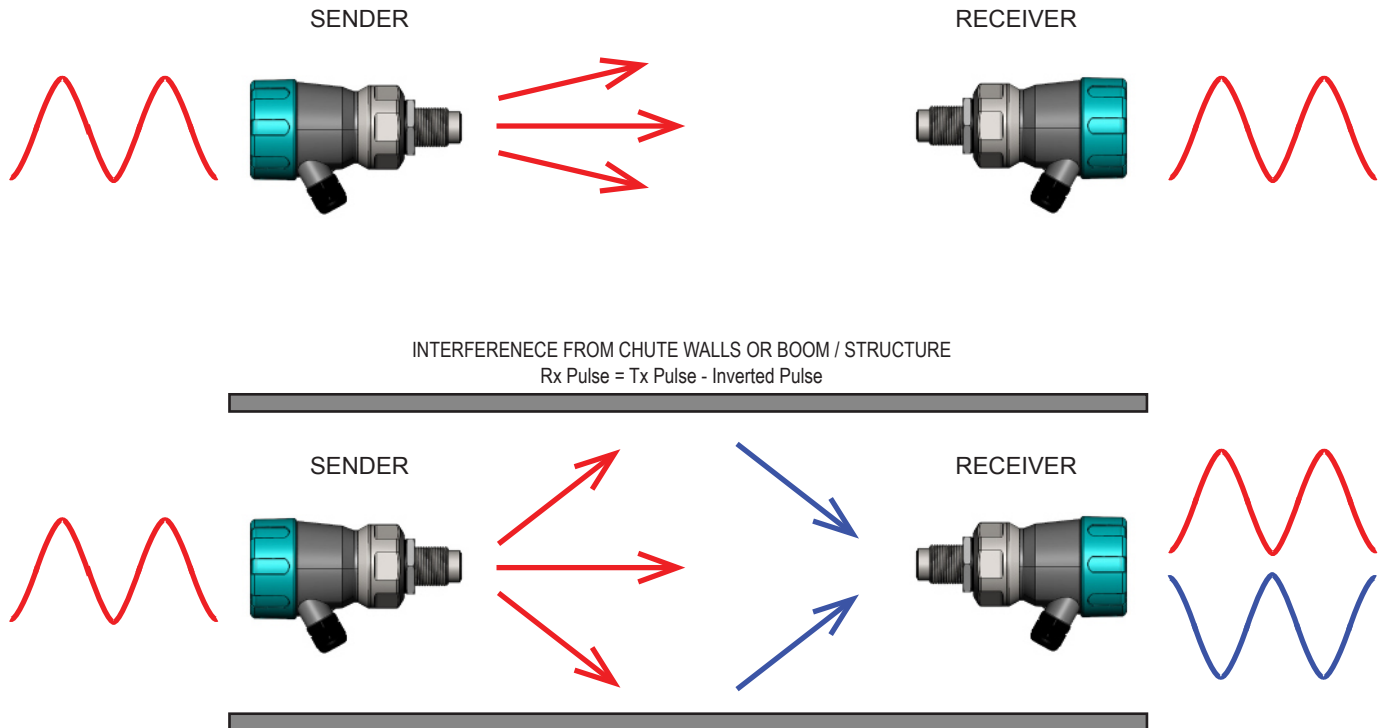

When a microwave transmitted signal comes in contact with an object, it will reflect. The amount of reflection and phase change depends on the objects dielectric constant. A linear receiver is not able to differentiate between the direct and the reflected signals; hence it will receive both and sum of the result is likely to be a smaller signal or worst-case no signal at all.

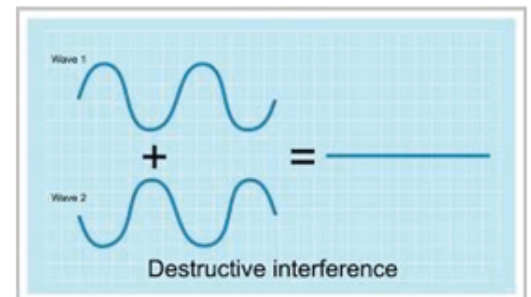
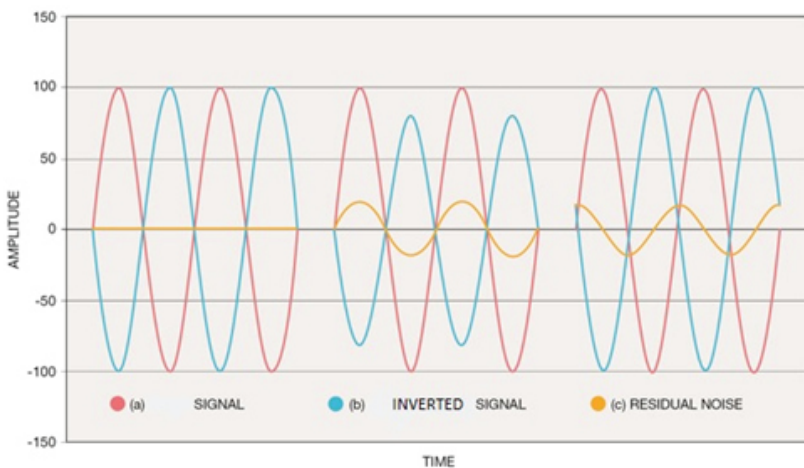

Linear vs Circular Polarisation

G1 Microwave Switch Series



G1 Microwave - Circular Polarisation

- Maximum Receiver Gain: 90,000
- Maximum Distance : 300m
- Beam Angle: 50°

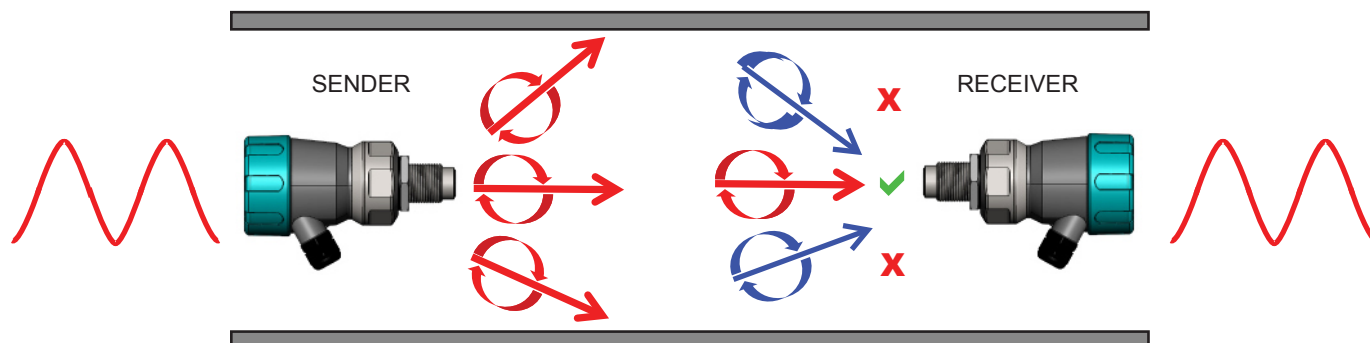

Circular polarization is either right handed or left handed. The HAWK Generation 3 system is right hand circular polarized. When a Circular polarized microwave transmitted signal comes in contact with an object it will reflect a left hand circular polarized transmitted signal, will then change to right hand circular polarized signal on the next reflection and vice versa with every reflection. If it is a single or odd number of reflections it will be a left hand polarized signal and if it is a two or even number of reflection then it will be a right hand polarized signal. The amount of reflection and phase change depends on the objects dielectric constant.

A HAWK Generation 3 receiver is designed to only receive a right hand circular polarized signal which means single or odd number of reflections (left hand circular polarized signals) will be ignored by the microwave receiver.

The only time a circular polarized system can be affected is when two or even numbers of reflection occur where the time delay or phase shift will start to cancel part of the signal. Due to multiple reflections, the amount of energy is smaller compared to the direct signal. Hence a circular polarized system will receive more signal than a linear polarized system, reducing the possibility of false trips.

Dimensions

G1 Microwave Switch Series



Microwave System

1" BSP or 1" NPT thread types available

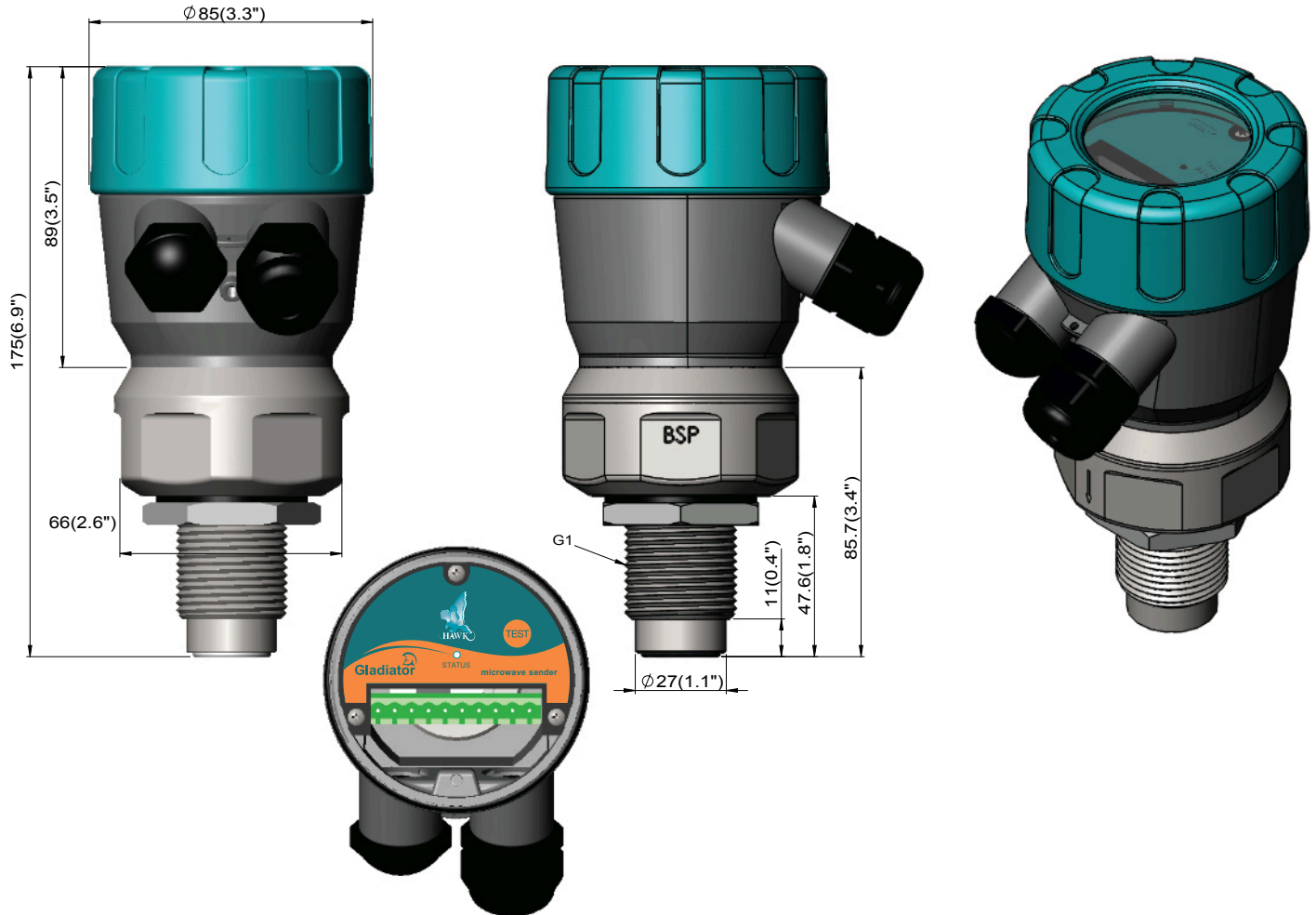



Weldment / Couplings with Windows

The weldment / couplings are designed to be welded into an appropriately sized hole in the vessel or application wall. A matching UHMW high wear window is then threaded into the weldment / coupling to act as a seal for the application. For Approval Option 2D Installations the Window is secured using a Locking Ring. See MD Series Windows and Weldments for further information.

This typical installation isolates the Microwave hardware from coming into contact with any damaging materials and allows simple maintenance or replacement of units without having to unseal the process / application.

The Microwave transmission will pass directly through plastics to measure the material in the process.

MA2 - 2" Weldment / coupling with UHMW windows

Isolated from process with Weldment / Coupling and window

Mount maximum 100mm (4") back from Window.

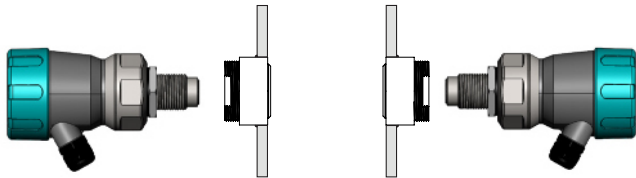

MA1 - 1" Weldment / coupling with UHMW window

Isolated from process with Weldment / Coupling and window

Mount maximum 100mm (4") back from Window.

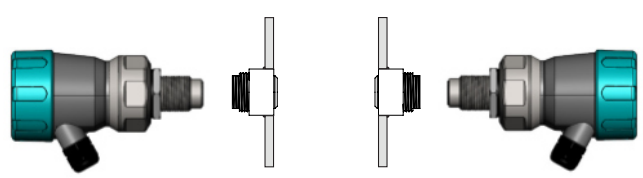

Isolated from process with Weldment / Coupling and window

Mounted to MA2-UW threaded window

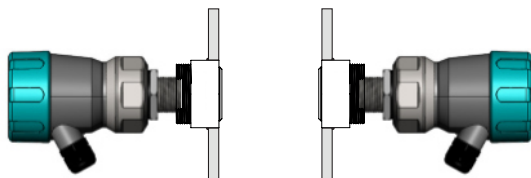

Sensing element within process

Mounted to MA1-WC threaded weldment / coupling

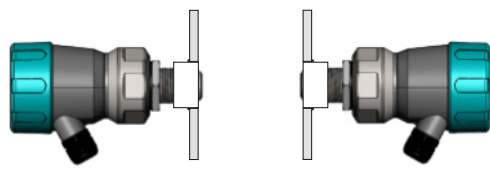

Mounting / Installation

G1 Microwave Switch Series



Waveguides

System with Waveguide extensions for remote mounting / signal transmission.

Waveguides can be used for difficult to access areas or to isolate the electronics from high temperature or non-compatible processes.

For further information on Waveguides see G1 Waveguide parts and assembly guide document available at <http://www.hawkmeasure.com>.

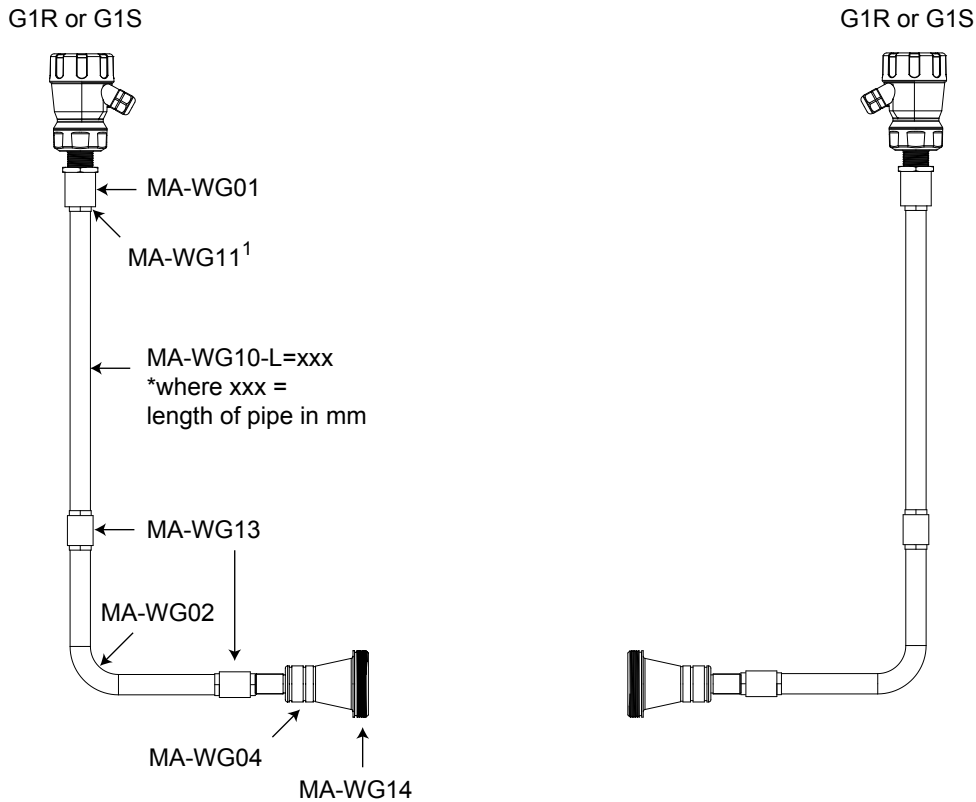

¹Displayed drawing includes qty 5 of MA-WG11 locking nut per side

Mounting Example

System with Waveguide extensions with MA2-WC-SS window and weldment/coupling application seal.

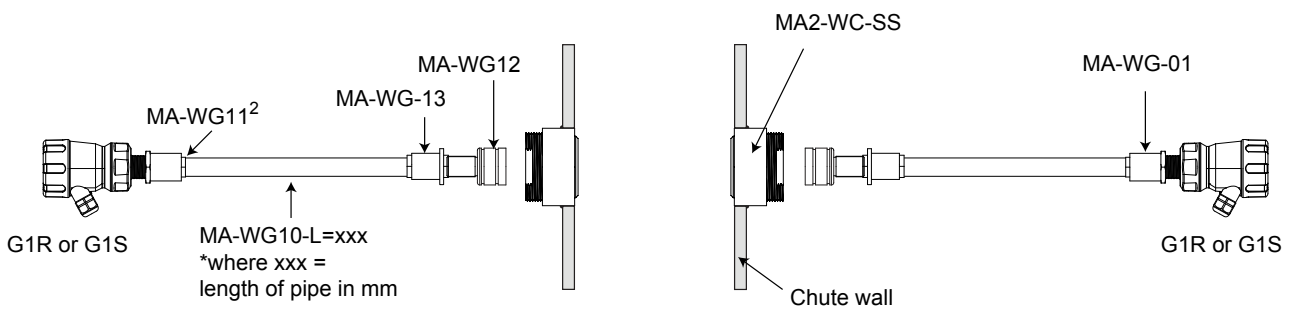

²Displayed drawing includes qty 3 of MA-WG11 locking nut per side



MA Series Mounting Accessories

Weldment / Couplings with Window for application seal

MA1

(consists of MA1-WC and MA1-UW)

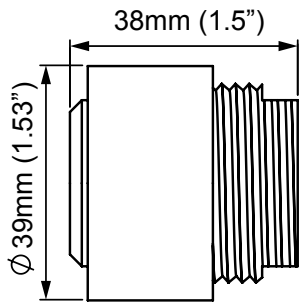

MA1-WC

Weldment / Coupling

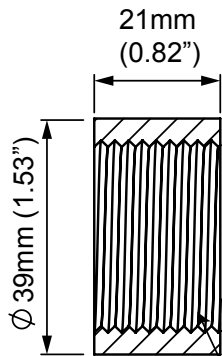

1" BSP
internal thread

MA1-UW

UHMW Window

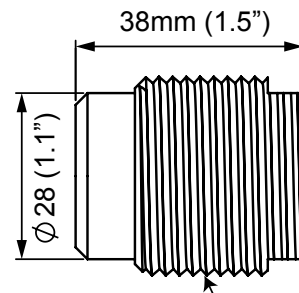

1" BSP
external thread

MA2

(consists of MA2-WC and MA2-UW)

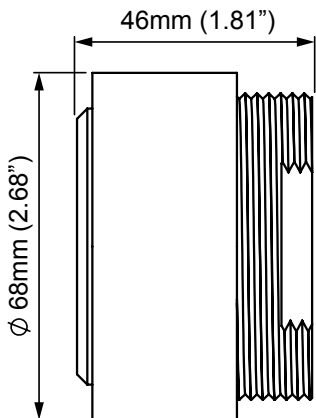

MA2-WC

Weldment / Coupling

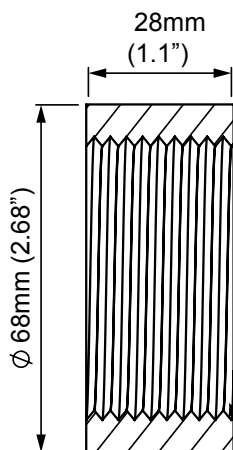

2" BSP
internal thread

MA2-UW

UHMW Window

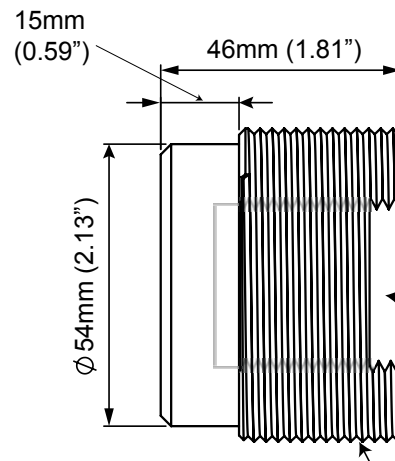

1" BSP/NPT
internal thread

2" BSP
external thread

Dimensions

G1 Microwave Switch Series



MD Series Weldments and Windows

Weldment with UHMW or PTFE Windows

The Weldment is welded to the vessel. The Window locks into the weldment using a locking ring.

For Approval Option 2D Installations. Consult Safety Instructions for critical details.

UHMW / PTFE Window

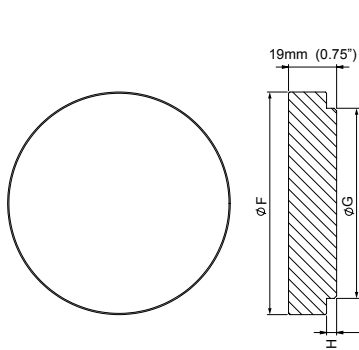

Weldment

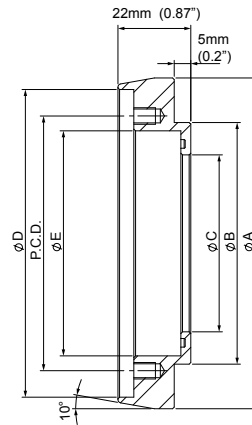
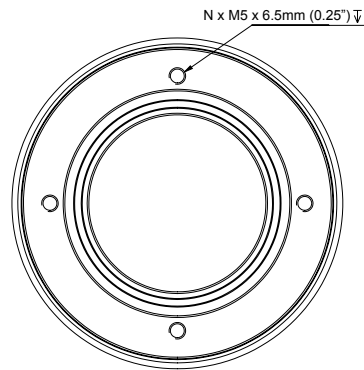

Assembled Piece

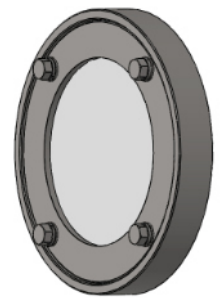

Part No ¹ .	Window Material	A		B		C		D		E		P.C.D		No. Holes
		mm	in	mm	in	mm	in	mm	in	mm	in	mm	in	
MD1-X	UHMW	75	3.0	48	1.9	29	1.1	68	2.7	43	1.7	52	2.0	4
MD2-X	UHMW	100	3.9	73	2.9	54	2.1	93	3.7	68	2.7	77	3.0	4
MD3-X	UHMW	122	4.8	93	3.7	77	3.0	115	4.5	90	3.5	99	3.9	4
MD6-X	PTFE	122	4.8	93	3.7	77	3.0	115	4.5	90	3.5	99	3.9	4

¹X = Weldment Material Selection

Part No ¹ .	Window Material	F		G		H		P.C.D		No. Holes
		mm	in	mm	in	mm	in	mm	in	
MD1-X	UHMW	43	1.7	28	1.1	4	1.6	52	2.0	4
MD2-X	UHMW	68	2.7	53	2.1	4	1.6	77	3.0	4
MD3-X	UHMW	89	3.5	76	3.0	4	1.6	99	3.9	4
MD6-X	PTFE	89	3.5	76	3.0	4	1.6	99	3.9	4

¹X = Weldment Material Selection

Dimensions

G1 Microwave Switch Series



Waveguides and Waveguide Accessories

MA-WG04

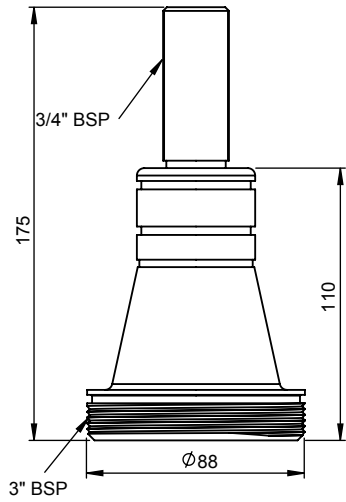

MA-WG04 with MA-WG14 window

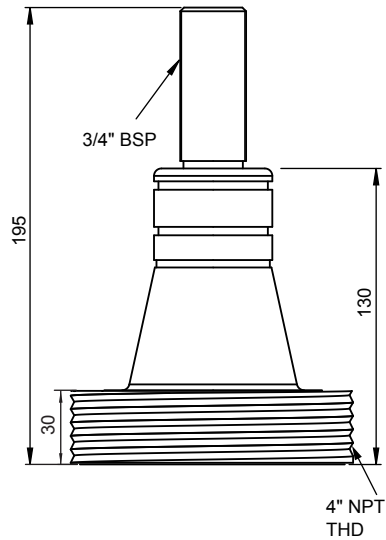

MA-WG03

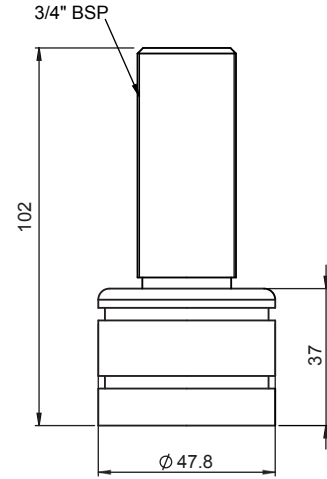

MA-WG12

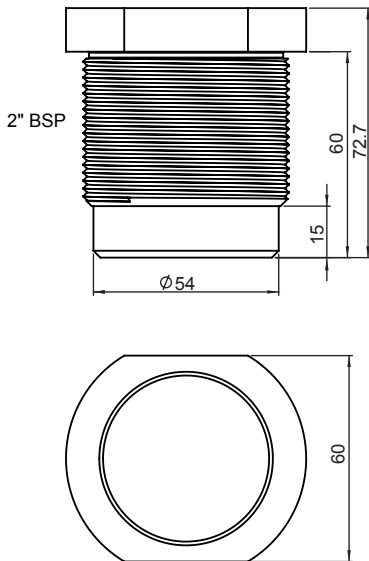

MA-WG02

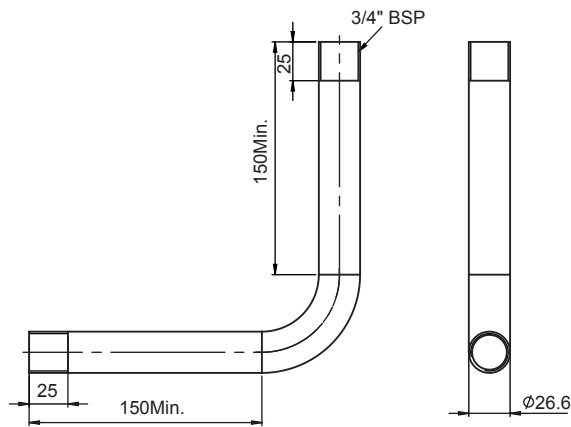

MA-WG12L=xxx

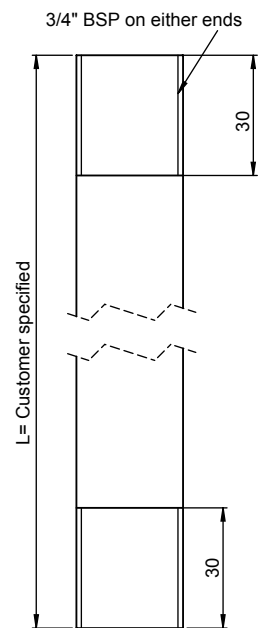

MA-WG-13

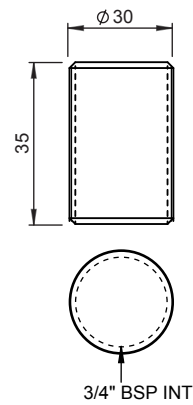

MA-WG01

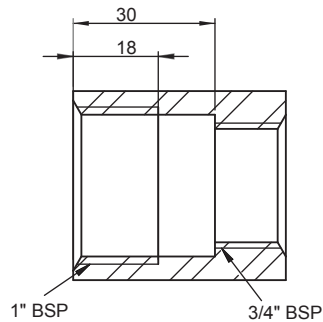
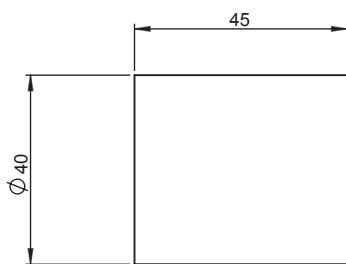

MA-WG11

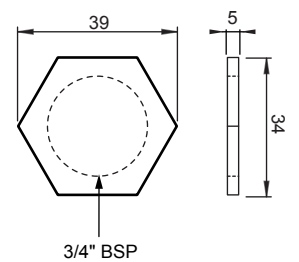



Remote System Connection - HAWK Supplied Cable

- The black wire of HAWK supplied cable comes with one end GND and the other GND / SHLD together.
- The GND / SHLD end is a larger cable which has been heat shrunk. The GND only end is the same size as the other cables.
- The GND / SHLD end must be connected to the amplifier.

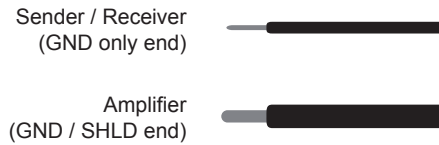

Remote Sender

Remote Receiver

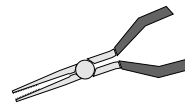

Use long nose pliers to extract terminals

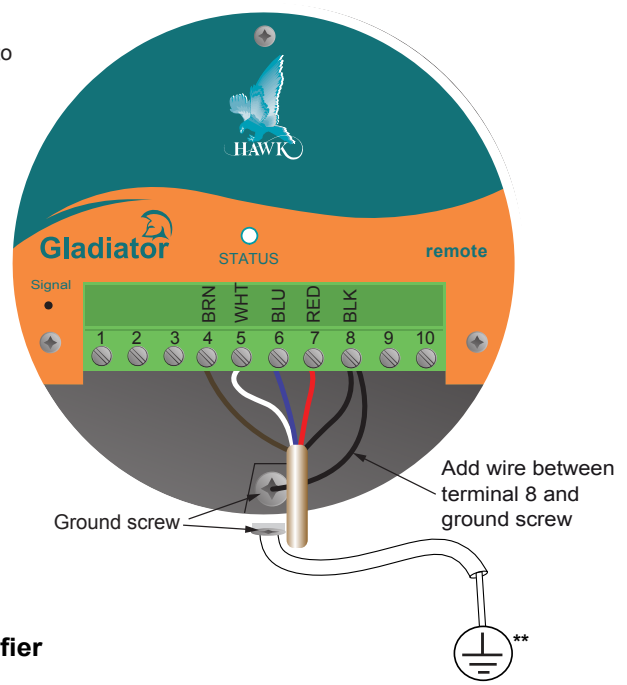
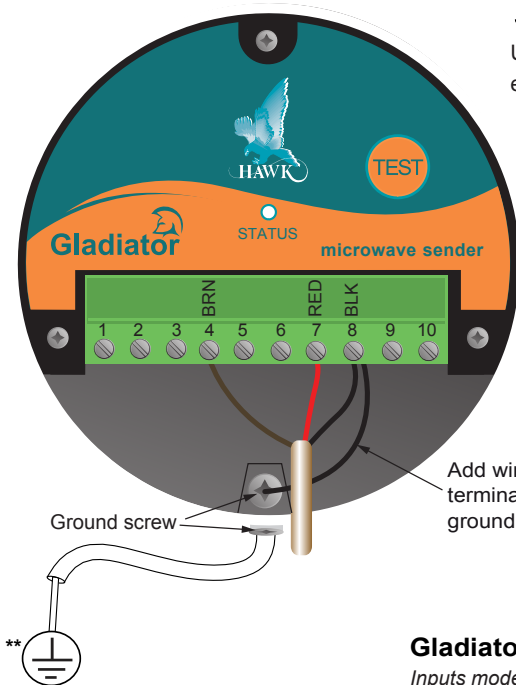

Gladiator Remote Amplifier

Inputs model dependent

			MIC-SENDER			SLAVE IN			MASTER OUT			RELAY 1			RELAY 2		
			RED	BLACK	BROWN	SLAVE IN	MASTER OUT	TEST IN	NC	COM	NO	NC	COM	NO			
16	17	18	19	20	21	22	23	24	25	26	27	28	29	30			
			Sender														
1	2	3	4	5	6	7	8	9	10	11	12	13	14	15			
Is	+	-	RED	BLACK	BLUE	WHITE	BROWN	B	A	-	+	⊕	⊖	⏏			
4-20mA			SENSOR				COMMS			DC-In			AC-In				

Remote Receiver

Remote Sender

Status LED

- Green when powered
- Blinks while working correctly
- Solid while not transmitting

TEST Button

- Press and hold to test level relay action

Remote Receiver

Status LED

- Green when powered
- High illumination = strong signal
- Low illumination = weak signal

Signal Contact

- Signal can be read with voltmeter across Signal contact point and earth screw (or other ground reference)
- 2.4-2.5V is full signal. 0V is no signal

*AC-In is replaced by 36-60VDC with Power Input Option 'C'.

**Ground the housing to vessel if vessel is metallic. Ground the housing to plant ground if vessel is non-metallic.



Integral System Connection

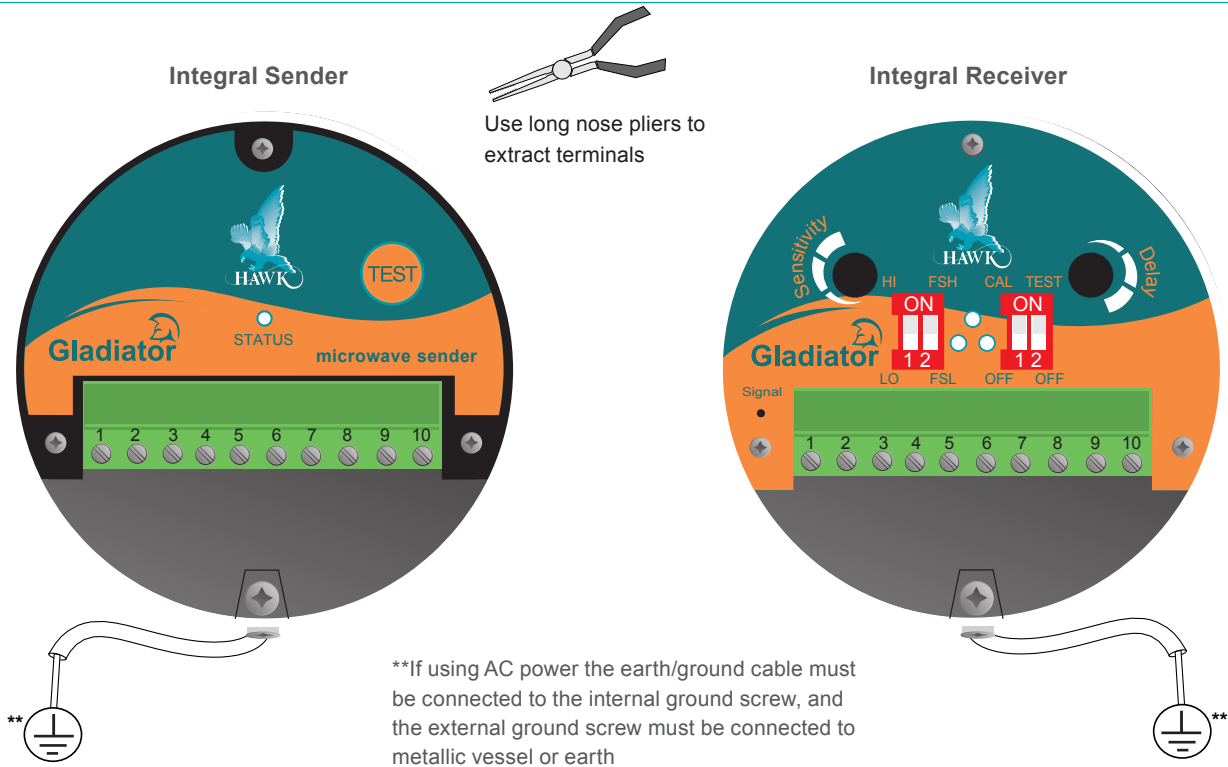

SENDER TERMINAL LAYOUT

						DC-IN		AC-IN	
1.	2.	3.	4.	5.	6.	+	-	N	L1
						12-30VDC		80-260VAC	

Terminals 1, 2, 3, 4, 5, 6 not used

RECEIVER TERMINAL LAYOUT

RELAY				COMMS		DC-IN		AC-IN	
1. NC	2. COM	3. NO	4. Test	A	B	+	-	N	L1
				Modbus D0 D1		12-30VDC		80-260VAC	

Sender

Status LED

Green when powered
Blinks while working correctly
Solid while not transmitting

TEST button

Press and hold to test level relay action

Receiver

Status LED

Green when powered
High illumination = strong signal
Low illumination = weak signal

Signal Contact

Signal can be read with voltmeter across Signal contact point and earth screw (or other ground reference)
2.4-2.5V is full signal. 0V is no signal

Part Numbers

G1 Microwave Switch Series



Remote Version

Remote Amplifier

GSA Gladiator Amplifier (compatible with all Gladiator products), Modbus

Housing

S Polycarbonate

Power Supply

B 12-30 VDC

C 36-60VDC

U 12-30VDC and 90-260VAC

Output Options

S 2 x SPDT relays

R 2 x SPDT Relays with Modbus Over Wi-Fi

X 2 x SPDT Relays with 4-20mA output

B 2 x SPDT Relays with Modbus Over Bluetooth

E 2 x SPDT Relays with Modbus Over Ethernet

Approval

A22 ATEX Grp II Cat 3 GD T85°C IP67 Tamb -40°C to 70°C

GSA S U S

Remote Sender / Receiver

Model

G1S Gladiator 1" Microwave Sender

G1T Gladiator 1" Microwave Remote Receiver

Electronics Housing

S Powder Coated Aluminium

C 316L Stainless Steel

Power Supply

B Not Required (Model G1S only)

X Not Required (Model G1T only)

Mounting Thread

TB 1" BSP

TN 1" NPT

Approvals

X Not Required

A22 ATEX Grp II Cat 3 GD T85°C IP67 Tamb -40°C to 70°C

2D IECEx ta tb IIIC T* Da Db Tamb = -30 to +80C

G1S C B TB X

**Consult Safety Instructions*

Part Numbering

G1 Microwave Switch Series



Integral Version

Model

- G1S** Gladiator 1" Microwave Sender
- G1R** Gladiator 1" Microwave Integral Receiver, 1 Relay with Failsafe
- G1Q** Gladiator 1" Microwave Integral Receiver with anti-crosstalk Sequenced software, 1 Relay with Failsafe. Requires GMSEQ Sequencer

Electronics Housing (Sensor element is 316L with Teflon face)

- S Powder Coated Aluminium
- C 316L Stainless Steel

Power Supply

- B 12-30VDC
- U 12-30VDC and 80-260VAC

Mounting Thread

- TB 1" BSP
- TN 1" NPT

Approvals

- X Not Required
- A22 ATEX Grp II Cat 3 GD T85°C IP67 Tamb -40°C to 70°C
- 2D IECEx ta tb IIIC T* Da Db Tamb = -30 to +80C

G1S C B TB X

**Consult Safety Instructions*

Microwave Sequencer

GMSEQ Gladiator Microwave Sequencer

Power Supply

- B 12-30VDC
- C 36-60VDC
- U 12-30VDC and 90-260VAC

GMSEQ U

MA Series Mounting Accessories

MA

- 1 1" UHMW Window & mild steel weldment/coupling each
- 1-SS 1" UHMW Window & 316L stainless steel weldment/coupling each
- 1-UW 1" UHMW Window each
- 1-WC 1" mild steel weldment/coupling each
- 1-WC-SS 1" 316L stainless steel weldment/coupling each
- 2 2" UHMW Window & mild steel weldment/coupling each
- 2-SS 2" UHMW Window & 316L stainless steel weldment/coupling each
- 2-UW 2" UHMW Window each
- 2-WC 2" mild steel weldment/coupling each
- 2-WC-SS 2" 316L stainless steel weldment/coupling each

MA 2

Additional mounting accessory variants and materials including high temperature ceramics are available.

See Gladiator Gen 3 Microwave datasheet available at www.hawkmeasure.com

Waveguides & Waveguide accessories

MA-WG

- 01 316L Threaded connector for Sender / Receiver
- 02 316L 90deg bend pipe (150mm + 150mm). Includes qty 2 of MA-WG11
- 03 316L 1-1/2" Wave guide horn. Includes qty 1 of MA-WG13
- 04 316L 3" Wave guide horn assembly. Includes qty 1 of MA-WG13
- 10-L=1 316L Straight pipe extension ¹L= length in mm. Includes qty 2 of MA-WG11
- 11 316L Locking nut
- 12 2" BSP teflon plug with socket to match MA-WG03 horn
- 13 316L Pipe to pipe connector coupling
- 14 4" Teflon window to match MA-WG04 Horn. Fits into MA18 weldment.

MA-WG 01

Part Numbers

G1 Microwave Switch Series



MD Series Mounting Accessories - Kit

For Approval Option 2D Installations. Consult Safety Instructions for critical details.

MD Mounting Accessories Kit

Window Facing Material

- 1 1" UHMW Window (-30°C to +75°C)
- 2 2" UHMW Window (-30°C to +75°C)
- 3 3" UHMW Window (-30°C to +75°C)
- 6 3" PTFE Window (-30°C to +200°C)

Weldment Material

- A SS304
- S SS316
- M Mild Steel

MD 3 - A

MD Series Mounting Accessories - Parts

For Approval Option 2D Installations. Consult Safety Instructions for critical details.

BASE Weldment Only

Weldment Size

- MD1 Matches MD1
- MD2 Matches MD2
- MD3 Matches MD3 & MD6

Material

- A SS304
- S SS316
- M Mild Steel

BASE - MD2 - A

WIN Window only

Window Facing Material

- MD1 UHMW for MD1 (-30°C to +75°C)
- MD2 UHMW for MD2 (-30°C to +75°C)
- MD3 UHMW for MD3 (-30°C to +75°C)
- MD6 PTFE for MD6 (-30°C to +200°C)

WIN - MD2

LRING Locking Ring Only

Ring Size

- MD1 Matches MD1
- MD2 Matches MD2
- MD3 Matches MD3 & MD6

Material

- A SS304
- S SS316
- M Mild Steel

LRING - MD2 - A

MD Series Part Combinations

Full Kit ¹	Size	Window	Weldment ¹	Locking Ring ¹
MD1-X	1"	WIN-MD1	BASE-MD1-X	LRING-MD1-X
MD2-X	2"	WIN-MD2	BASE-MD2-X	LRING-MD2-X
MD3-X	3"	WIN-MD3	BASE-MD3-X	LRING-MD3-X
MD6-X	3"	WIN-MD6	BASE-MD3-X	LRING-MD3-X

¹X = Material Selection

Notes

G1 Microwave Switch Series



Specifications

G1 Microwave Switch Series



Operating Voltage

- 12-30VDC (residual ripple no greater than 100mV)
- 80-260VAC.

Power Consumption

- <0.8W @ 24VDC
- <3VA @ 115VAC
- <5VA @ 240VAC.

Communications

- GosHawk, Modbus, Modbus over Ethernet / Wi Fi / Bluetooth
- Multidrop mode can address 1-250 units over 4 wires.

Relay Output

- Remote: 2 x SPDT Form 'C' contacts, rated 5A at 240VAC resistive
- Integral: 1 x SPDT Form 'C' contacts, rated 5A at 240VAC resistive
- Remote fail-safe test facility for one relay.

Operating Temperature

- -30°C (-20°F) to 65°C (150°F).
- *For higher temperature applications, remote waveguide mounting with appropriate windows is necessary.*

Power Density

- Rated from emitter to receiver at approximately 20μW/cm²
- Complies with FCC Title Rules Part 15 (Beam Blockage)
- Caution sign posting not required.

Transmitted Signal

- Circular polarisation polarity
- Sensitivity -88dBm
- Frequency: 10.525GHz
- Beam width 50°
- Power: +14dBm / 25mW.

Fail-Safe

- Selectable - presence or absence of material
- High level fail-safe: relay is activated when material is present
- Low level fail-safe: relay is activated when no material is present.

Range

- Theoretical Maximum range: 300m (984ft)
 - Recommended Range (Chutes) 15m
 - Recommended Range (Object detection) 50m
 - Minimum range under ideal conditions: 10cm (4 inches).
- Note: Minimum ranges are dependent on application conductivity.*

Maximum Operating Pressure

- 10 BAR (145psig).

Enclosure Sealing

- G1S/G1T/G1R: IP66/67 • GSA: IP65 / NEMA 4X

Wetted Materials

- Sensing element housing: 316L stainless steel
- Sensing element face: Teflon.

Cable Entries

- Integral Units: 2 x M20 Glands / 3/4" NPTF threaded adaptors.

Mounting

- 1" NTP
- 1" BSP

Remote Test Input

- Press to test (used to check for malfunction of unit from remote position, PLC, SCADA etc).

Weight

- G1R/G1S/G1T 1kg
- GSA 1kg.

Approval

- IECEx Zone 20/21, Zone 21
- Ex ta tb IIIC T* Da Db Tamb = -30 to +80C
- IP66.

**Consult Safety Instructions
Specifications model dependent*

Hawk Measurement Systems (Head Office)

15 - 17 Maurice Court
Nunawading VIC 3131, AUSTRALIA
Phone: +61 3 9873 4750
Fax: +61 3 9873 4538
info@hawk.com.au

For more information and global representatives: www.hawkmeasure.com

Additional product warranty and application guarantees upon request.
Technical data subject to change without notice.

Hawk Measurement

90 Glenn Street
Suite 100B, Lawrence, MA 01843, USA
Phone: +1 888 HAWKLEVEL (1-888-429-5538)
Phone: +1 978 304 3000
Fax: +1 978 304 1462
info@hawkmeasure.com

Represented by:

