

A Higher Level of Performance



Data Sheet

Centurion Guided Radar



For more information, please visit >
www.hawkmeasurement.com

Overview

Centurion Guided Radar



Description

The Centurion Guided Radar (CGR) Level Transmitter is ideal for the measurement of liquids, sludge, powders and granules to a range of 38m (124ft) for level and interface measurement. This award-winning technology is not affected by pressure, temperature, viscosity, vacuum, foam, dust, changes in dielectric constant or coating of the probe. HAWK's CGR won the prestigious Chemical Processing 2021 Vaaleer Awards.

HAWK's CGR is the first and only guided wave radar on the market to feature Power over Ethernet (PoE) communications. The advantages to PoE connectivity are secure in-plant and remote monitoring, as well as remote sensor setup, diagnostics and troubleshooting abilities.

Primary Areas of Application

- Chemicals
- Petrochemicals
- Cement
- Building Aggregates
- Mining / Minerals
- Food & Beverages
- Oil & Gas
- Pharmaceutical
- Pulp & Paper
- Wastewater



Principle of Operation

Guided-wave technology sends the radar pulse down a probe to measure either liquids, solids or a low dielectric to high dielectric Interface level.

The pulse hits the surface and / or Interface and is reflected back up the probe to the sensor, where the transit time is translated into a distance using time of flight and time expansion. The amplitude of the reflection depends on the dielectric constant of the product.

Features

- Hazardous rated for Gas & Dust with IECEx, FM, CSA & ATEX
- Safety Rated to SIL2, SIL3 (multi channel)
- First Powered Ethernet (PoE) Enabled GWR in the Industry
- Interface Level measurement option
- Up to 38m (124ft) range
- Very short minimum range ($\leq 150\text{mm}$, 6")
- Simple setup
- Auto-calibration to any dielectric ≥ 1.5
- Automatic Sensitivity Control
- Precise & continuous measurement
- 4-20mA with HART 7
- Protection class IP66, NEMA 4x
- Measures extremely low dielectric (1.5)
- Programmable fail safe mode

Overview

Centurion Guided Radar



Power over Ethernet (PoE) Communication

Hawk Measurement (HAWK) created the industry's first and only Guided Wave Radar level transmitter that features Power over Ethernet (PoE) communications. The advantages to PoE connectivity are secure in-plant and remote monitoring, as well as remote sensor setup, diagnostics and troubleshooting abilities. The Centurion Guided Radar (CGR) Level Transmitter is ideal for the measurement of liquids, sludge, powders and granules to a range of 38m (124ft) for level and interface measurement.

If troubleshooting is required, the CGR PoE will communicate to remote service technicians for off-site diagnostics, sensor health and re-configuration, without the need to climb a tank or enter the facility. HAWK's CGR PoE can connect to an online portal, the HawkEye365, which can monitor multiple tanks worldwide in real-time. The portal provides accessibility to critical data such as the ability to view volume, space, material height, historical trending, alarms and alerts, sensor setup and diagnostics. Plant level operator screens are customized to the company's specifications to include control room level and operations level interface screens. The graphical user interface will be common throughout and permissions can be set for different tiers such as plant-level, finance, or executive level.



PoE Features

- Remotely monitor tank levels from smart phone, tablet, or computer
- Real-time tank monitoring from online portal
- Receive tank alarms and alerts to phone and email
- Secure in-plant and remote monitoring
- Remote sensor setup
- Remote diagnostics and troubleshooting abilities

Awards





HART Units

Dual Chamber

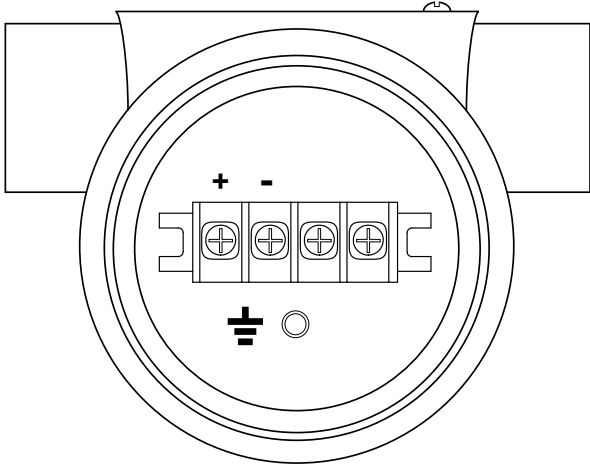

Single Chamber

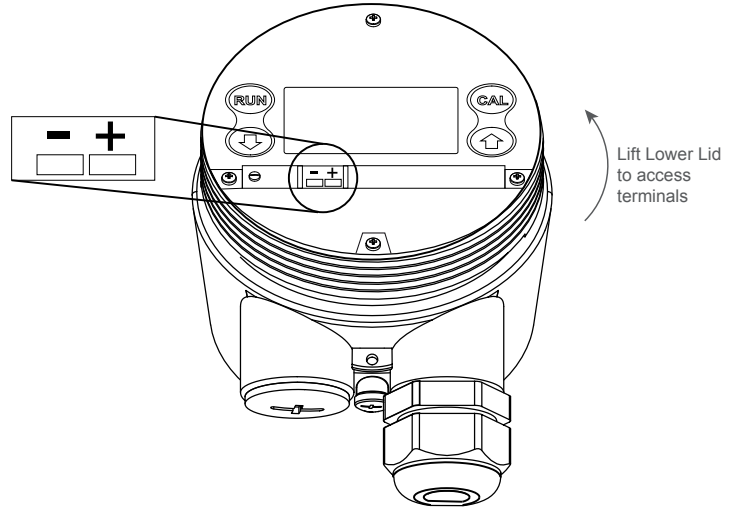

Modbus / Ethernet Units

Dual Chamber

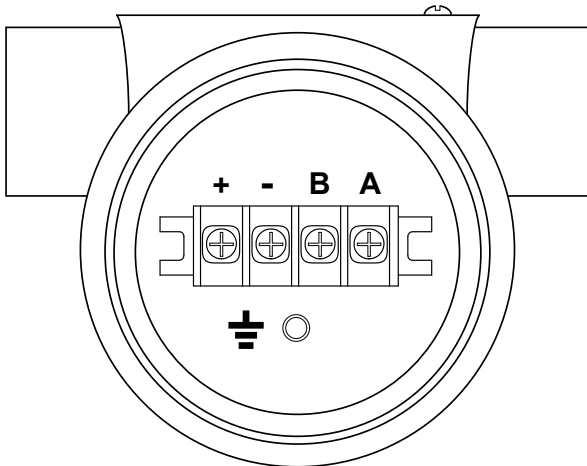

Single Chamber

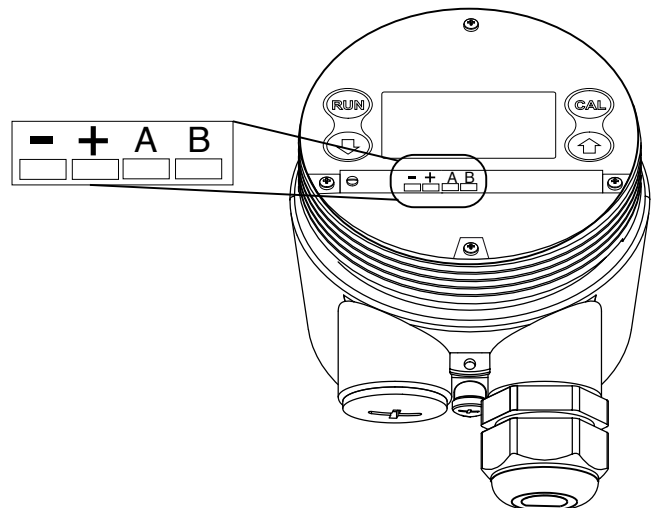



Dimensions - Housing

Dual Chamber

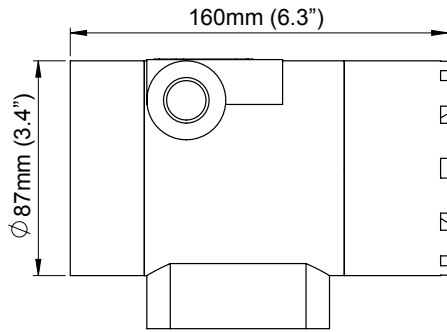

Process Temperature
 $\leq 130^{\circ}\text{C}$ (266°F)

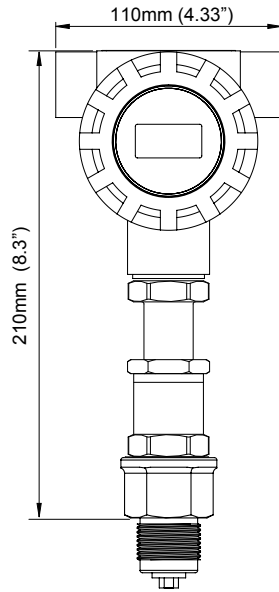

Process Temperature
 $150^{\circ}\text{C} \geq 325^{\circ}\text{C}$ (302°F \geq 617°F)

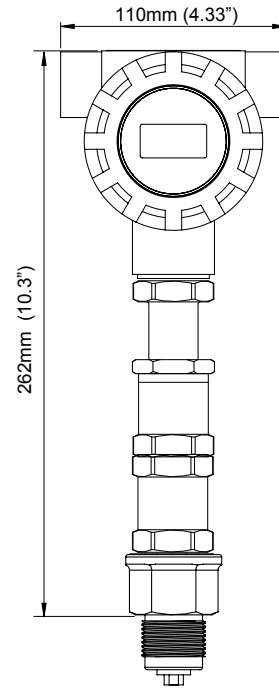

Single Chamber with Viewing Window

Process Temperature
 80°C (176°F)

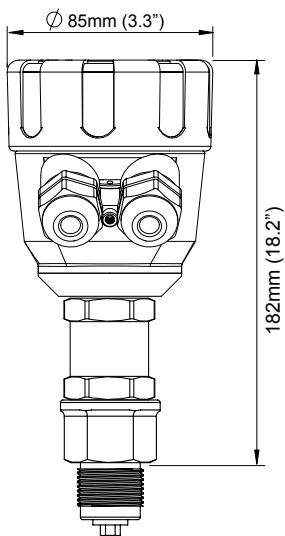

Process Temperature
 $130^{\circ}\text{C} \geq 325^{\circ}\text{C}$ (266°F \geq 617°F)

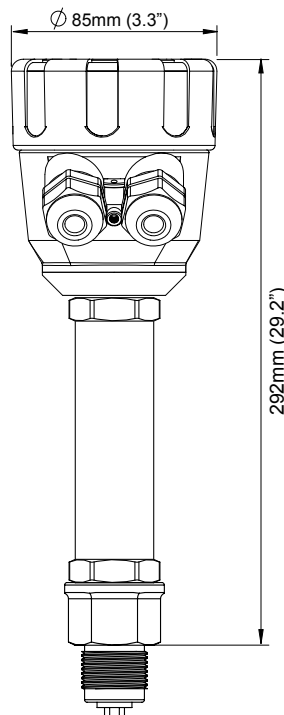

Single Chamber with no Viewing Window

Process Temperature
 80°C (176°F)

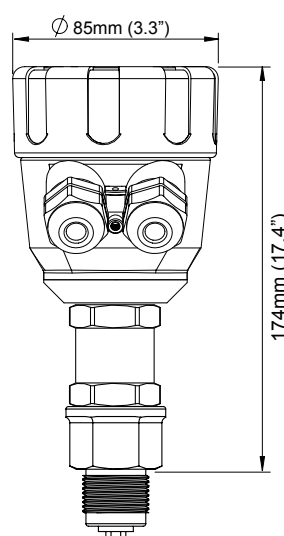

Process Temperature
 $130^{\circ}\text{C} \geq 325^{\circ}\text{C}$ (266°F \geq 617°F)

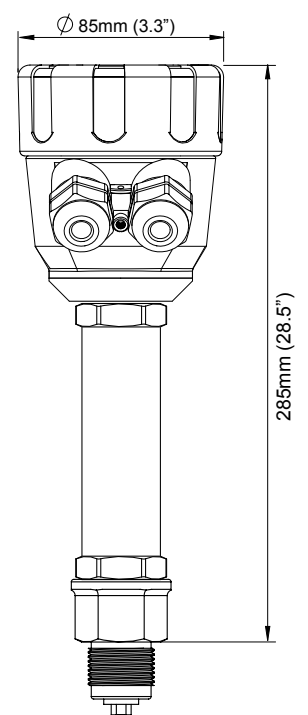



Dimensions - Probe Variants

A04 / A06 / A08 / J04 / J06 / J08

B04 / B06 / B08 / K04 / K06 / K08 / B11

Threaded

Flanged Bush

Threaded

Flanged Bush

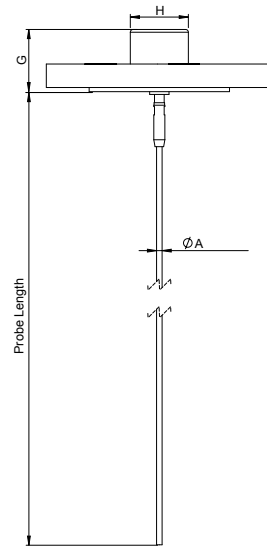
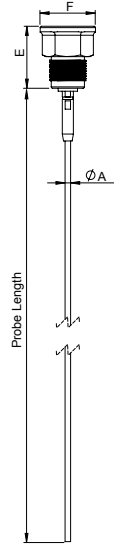
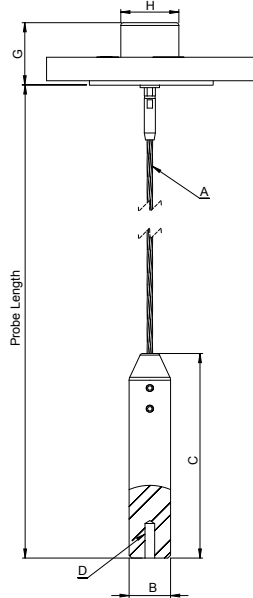
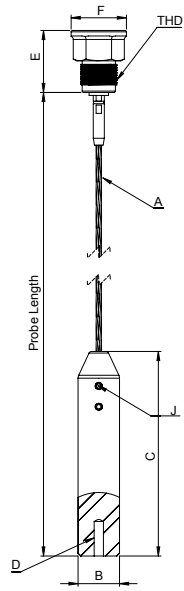

Probe / Cable Dimensions

Probe Type	THD BSP or NPT	A		B		C		E		F		D Internal Threads (A04, A06, A08 only)	J (Tightening Torque = 20Nm)	
	in.	mm	in.	mm	in.	mm	in.	mm	in.	mm	in.		Set Screw	Hex Key Size
A04, B04, J04, K04	3/4	4	0.16	22	0.9	120	4.7	45	1.8	40	1.6	M10x1.25, 24mm deep	3x M8x1.25x12	4mm
A06, B06, J04, K04	1	6	0.24	28	1.1	150	5.9	45	1.8	40	1.6	M10x1.25, 24mm deep	3x M8x1.25x12	4mm
B11	1	6	0.43	NA	NA	NA	NA	NA	NA	40	1.6	NA	NA	NA
A08, B08, J04, K04	1-1/2	8	0.31	36	1.4	200	7.8	72	2.8	64	2.5	M10x1.25, 24mm deep	3x M10x1.5x18	5mm
	Flanged Bush	G		H										
		mm	in.	mm	in.									
A04, B04, J04, K04, A06, B06, J06, K06, B11		45	1.8	42	1.6									
A08, B08, J04, K04		72	2.8	70	2.7									



Centurion Guided Radar System

3/4" & 1" Threaded Units (mounting option TN07, TB07, TN10, TB10, Flanged)

Model

CGR2 2 wire Centurion Guided Radar

CGR4 4 wire Centurion Guided Radar

Communication

H 4-20mA with HART 7⁶

L 4-20mA with HART 7 and SIL2⁶

M Modbus⁷

E Modbus over PoE (Powered Ethernet). HawkEye365 compatible^{7,8}

Housing

- | | | | |
|---|---|---|--|
| 1 | Dual Chamber Aluminium, epoxy painted with viewing window | A | Single Chamber Aluminium, powder coated with viewing window ⁴ |
| 2 | Dual Chamber 316L Stainless Steel, with viewing window | B | Single Chamber Aluminium, powder coated, no viewing window ⁴ |
| C | Single Chamber 316L Stainless Steel with viewing window ⁴ | D | Single Chamber 316L Stainless Steel with no viewing window ⁴ |
| E | Blind Housing (ABS Thermoplastic) with 800mm remote probe coaxial cable connection. Approval option XX only, M20 conduit only | | |

Conduit / Cable Entry

1 1/2" NPT

3 M20 x 1.5

Probe Type

A04 4mm flexible cable

A06 6mm flexible cable

B04 4mm rigid probe

B06 6mm rigid probe

J04 Detached 4mm flexible cable

J06 Detached 6mm flexible cable

K04 Detached 4mm rigid probe

K06 Detached 6mm rigid probe

C04 Coaxial / 4mm probe

C06 Coaxial / 6mm probe

B11 11mm segmented rigid probe (TB10/TN10 mounting only). Requires B11 Probe Segments Accessory

Probe Variant / Materials

S 316L T 316L with CRN (Mounting TB/TN only)

L Monel 400 K Monel 400 with CRN (Mounting TB/TN only)

P PTFE

Mounting

TN07 3/4" NPT Thread

TB07 3/4" BSP Thread

TN10 1" NPT Thread

TB10 1" BSP Thread

FXXX¹ Flanged Bush (replace XXX with 3 character Flanged Bush Code)

Process O-ring Seal / Process Temperature

V1 FKM (Viton) (-40°C to +80°C) (-40°F to +176°F)

V4 FKM (Viton) (-40°C to +150°C) (-40°F to +302°F)

B1 NBR (-40°C to +80°C) (-40°F to +176°F)

E1 EPDM (-40°C to +80°C) (-40°F to +176°F)

E3 EPDM (-40°C to +130°C) (-40°F to +266°F)

M1 FFKM (Markez) (-10°C to +80°C) (+14°F to +176°F)

M4 FFKM (Markez) (-10°C to +150°C) (+14°F to +302°F)

M5 FFKM (Markez) (-10°C to +200°C) (+14°F to +392°F)

M6 FFKM (Markez) (-5°C to +250°C) (+23°F to +482°F) (Max Process Pressure 40 bar)

M8 FFKM (Markez) (-5°C to +325°C) (+23°F to +617°F) (Max Process Pressure 6 bar)

S1 Silicone (-40°C to +80°C) (-40°F to +176°F)



Process Pressure

- 1 6 bar (87 psig)
- 3 20 bar (290 psig)
- 4 40 bar (580 psig)
- 5 100 bar (1450 psig)

Approval Standard

- XX Not Required
- 1D IECEx Ex ia/db [ja Ga] IIC T6...T2 Ga/Gb
- 2D IECEx Ex ia tb [ja Da] IIIC T85°C...T250°C Da Db
- 1U FM XP CI I, Div 1, Gp B-D with IS Probe CI I, Div I, Gp A-D, T6...T2B, Ta = T* to 60°C; CI. I Zone 0/1 AEx ia/db [ja Ga] IIC T6...T2 Ga/Gb
- 2U FM DIP-IS, CI II, III, Div 1, Grp E, F and G, T6...T2B, Ta = T* to +60°C; Zone 20/21 AEx ia IIIC T85°C...T250°C Da; AEx tb IIIC T85°C Db, Ta = T* to +60°C
- GP FM/CSA General Purpose
- 1C CSA XP CI I, Div 1, Gp B-D with IS Probe CI I, Div I, Gp A-D, T6...T2B³
- 2C CSA Ex ia/db IIC T6...T2 Ga/Gb³
- 3C CSA DIP-IS, Class II, III, Division 1, Groups E, F and G, T6...T2B³
- 4C CSA Ex ia IIIC T85°C...T250°C Da; Ex tb IIIC T85°C Db³
- 1A ATEX II 1/2 G Ex ia/db IIC T6...T2 Ga/Gb
- 2A ATEX II 1/2 D Ex ia IIIC T85°C...T250°C Da / Ex tb IIIC T85°C Db
- 3A ATEX II 3 G Ex ic/dc IIC T6... T2 Gc Tamb -40°C to 60°C
- 6A ATEX II 3 D Ex ia IIIC T85°C...T255°C Dc Tamb -40°C to 60°C, Ex tb IIIC T85°C Dc⁵
- 6A ATEX II 3 D Ex tc IIIC T85°C ... T250°C Dc Tamb -40°C to 60°C

Probe Length

Specify in cm

Option

H Interface Level Software (Leave blank if not required).

CGR2 H 1 3 B04 S TN10 B1 1 XX 200

Probe Type 'B11' Segmented Probe Pieces

CGR-B11SEG-S-XX-L= (L = Specify length of piece in cm. Material 316L. No centering disc)

CGR-B11SEG-S-CD-L= (L = Specify length of piece in cm. Material 316L. With centering disc, must be end piece only)

Probe / Mounting Combination Table

Probe Code	Variant / Materials	Mounting	Flange Sizes ²		Max. Length
			Min. Size	Max size	
A04 / J04	S, L, P, T, K	TN07, TB07, FXXX	1", DN25, 25mm	4", DN100, 100mm	3800cm
A06 / J06	S, L, P, T, K	TN10, TB10	2", DN50, 50mm	4", DN100, 100mm	3800cm
B04 / K04	S, L, T, K	TN07, TB07, FXXX	1", DN25, 25mm	4", DN100, 100mm	400cm
B06 / K06	S, L, T, K	TN10, TB10	2", DN50, 50mm	4", DN100, 100mm	400cm
B11	S, L, T, K	TN10, TB10	2", DN50, 50mm	4", DN100, 100mm	600cm

¹See Flangd Bush selection in Flange Table. Not available with CRN

²HAWK Supplied Flanges. End user can use any appropriate flange with suitable bore hole.

³NPT conduit / cable thread only

⁴Hazardous Approval 'XX, 6A' only

⁵Housing Option A, B only

⁶Model type 'CGR2' only

⁷Model type 'CGR4' only

⁸Housing option 'A, B, C, D' only. Approval Standard 'XX' only

* Refer to Safety Instructions



Centurion Guided Radar System

1.5" Threaded Units (mounting option TN15, TB15, Flanged)

Model

- CGR2 Centurion Guided Radar 2 Wire
CGR4 4 wire Centurion Guided Radar

Communication

- H 4-20mA with HART 7⁶
L 4-20mA with HART 7 and SIL2⁶
M Modbus⁷
E Modbus over PoE (Powered Ethernet). HawkEye365 compatible^{7,8}

Housing

- | | | | |
|---|---|---|--|
| 1 | Dual Chamber Aluminium, epoxy painted with viewing window | A | Single Chamber Aluminium, powder coated with viewing window ⁴ |
| 2 | Dual Chamber 316L Stainless Steel, with viewing window | B | Single Chamber Aluminium, powder coated, no viewing window ⁴ |
| C | Single Chamber 316L Stainless Steel with viewing window ⁴ | D | Single Chamber 316L Stainless Steel with no viewing window ⁴ |
| E | Blind Housing (ABS Thermoplastic) with 800mm remote probe coaxial cable connection. Approval option XX only, M20 conduit only | | |

Conduit / Cable Entry

- 1 1/2" NPT 3 M20 x 1.5

Probe Type

- A08 8mm flexible cable
B08 8mm rigid probe
J08 Detached 8mm flexible cable
K08 Detached 8mm rigid probe
C08 Coaxial / 8mm probe

Probe Variant / Materials

- | | | | |
|---|-----------|---|--|
| S | 316L | T | 316L with CRN (Mounting TB/TN only) |
| L | Monel 400 | K | Monel 400 with CRN (Mounting TB/TN only) |
| P | PTFE | | |

Mounting

- TN15 1.5" NPT
TB15 1.5" BSP
FXXX¹ Flanged Bush (no threaded connection) (replace XXX with 3 character Flanged Bush Code)

Process O-ring Seal / Process Temperature

- | | | | |
|----|-------------|-------------------|---|
| V1 | FKM (Viton) | (-40°C to +80°C) | (-40°F to +176°F) |
| V3 | FKM (Viton) | (-40°C to +130°C) | (-40°F to +266°F) |
| B1 | NBR | (-40°C to +80°C) | (-40°F to +176°F) |
| E1 | EPDM | (-40°C to +80°C) | (-40°F to +176°F) |
| E3 | EPDM | (-40°C to +130°C) | (-40°F to +266°F) (Max. Process Pressure 6 bar / 87 psig) |
| S1 | Silicone | (-40°C to +80°C) | (-40°F to +176°F) |
| S3 | Silicone | (-40°C to +130°C) | (-40°F to +266°F) (Max. Process Pressure 6 bar / 87 psig) |

Process Pressure

- 1 6 bar (87 psig)
3 20 bar (290 psig)
4 40 bar (580 psig)

Approval Standard

- XX Not Required



- 1D IECEx Ex ia/db [ia Ga] IIC T6...T2 Ga/Gb
- 2D IECEx Ex ia tb [ia Da] IIIC T85°C...T250°C Da Db
- 1U FM XP CI I, Div 1, Gp B-D with IS Probe CI I, Div I, Gp A-D, T6...T2B, Ta = T* to 60°C; CI. I Zone 0/1 AEx ia/db [ia Ga] IIC T6...T2 Ga/Gb
- 2U FM (USA) DIP-IS, CI II, III, Div 1, Grp E, F and G, T6...T2B, Ta = T* to +60°C; Zone 20/21 AEx ia IIIC T85°C...T250°C Da; AEx tb IIIC T85°C Db, Ta = T* to +60°C
- GP FM/CSA General Purpose
- 1C CSA XP CI I, Div 1, Gp B-D with IS Probe CI I, Div I, Gp A-D, T6...T2B³
- 2C CSA Ex ia/db IIC T6...T2 Ga/Gb³
- 3C CSA DIP-IS, Class II, III, Division 1, Groups E, F and G, T6...T2B³
- 4C CSA Ex ia IIIC T85°C...T250°C Da; Ex tb IIIC T85°C Db³
- 1A ATEX II 1/2 G Ex ia/db IIC T6...T2 Ga/Gb
- 2A ATEX II 1/2 D Ex ia IIIC T85°C...T250°C Da / Ex tb IIIC T85°C Db
- 3A ATEX II 3 G Ex ic/dc IIC T6... T2 Gc Tamb -40°C to 60°C
- 6A ATEX II 3 D Ex ia IIIC T85°C...T255°C Dc Tamb -40°C to 60°C, Ex tb IIIC T85°C Dc⁵
- 6A ATEX II 3 D Ex tc IIIC T85°C ... T250°C Dc Tamb -40°C to 60°C

Probe Length

Specify in cm

Option

H Interface Level Software (Leave blank if not required).

CGR2 H 1 3 B08 S TN15 B1 1 XX 200

Probe / Mounting Combination Table

Probe Code	Variant / Materials	Mounting	Flange Sizes ²		Max. Length
			Min. Size	Max size	
A08 / J08	S, L, P, T, K	TN15, TB15, FXXX	2", DN50, 50mm	4", DN100, 100mm	3800cm
B08 / K08	S, L, T, K	TN15, TB15, FXXX	2", DN50, 50mm	4", DN100, 100mm	400cm

¹See Flanged Bush selection in Flange Table.

²HAWK Supplied Flanges. End user can use any appropriate flange with suitable bore hole.

³NPT conduit / cable thread only

⁴Hazardous Approval 'XX, 6A' only

⁵Housing Option A, B only

⁶Model type 'CGR2' only

⁷Model type 'CGR4' only

⁸Housing option 'A, B, C, D' only. Approval Standard 'XX' only

* Refer to Safety Instructions



Mounting Flanges

Threaded Flanges

Model

FLA - **Flange Size**

- 1 1" or DN25 or 25mm
- H 1 1/2" or DN40 or 40mm
- 2 2" or DN50 or 50mm
- K 2 1/2" or DN65 or 65mm
- 3 3" or DN80 or 80mm
- L 3 1/2" (ANSI ONLY)
- 4 4" or DN100 or 100mm

Flange Type

- A1 ANSI B16.5 150LB FLANGE
- A3 ANSI B16.5 300LB FLANGE
- A6 ANSI B16.5 600LB FLANGE
- A9 ANSI B16.5 900LB FLANGE
- AA ANSI B16.5 1500LB FLANGE
- AB ANSI B16.5 2500LB FLANGE
- D6 DIN2527 PN6 FLANGE
- D0 DIN2527 PN10 FLANGE
- D1 DIN2527 PN16 FLANGE
- D2 DIN2527 PN25 FLANGE
- D4 DIN2527 PN40 FLANGE
- J5 JIS 5K FLANGE
- J0 JIS 10K FLANGE
- J1 JIS 16K FLANGE
- J2 JIS 20K FLANGE
- J4 JIS 40K FLANGE
- S1 AS 2129 Table D
- S2 AS 2129 Table E
- S3 AS 2129 Table F
- S4 AS 2129 Table H

Material

SS SS316L

Thread Type

- TB07 3/4" BSP THDs
- TB10 1" BSP THDs
- TB15 1 1/2" BSP THDs
- TN07 3/4" NPT THDs
- TN10 1" NPT THDs
- TN15 1 1/2" NPT THDs

FLA - 2 A1 - SS - TB15

Flanged Bush

Model

F **Flange Size**

- 1 1" or DN25 or 25mm
- H 1 1/2" or DN40 or 40mm
- 2 2" or DN50 or 50mm
- K 2 1/2" or DN65 or 65mm
- 3 3" or DN80 or 80mm
- L 3 1/2" (ANSI ONLY)
- 4 4" or DN100 or 100mm

Flange Type

- A1 ANSI B16.5 150LB FLANGE
- A3 ANSI B16.5 300LB FLANGE
- A6 ANSI B16.5 600LB FLANGE
- A9 ANSI B16.5 900LB FLANGE
- AA ANSI B16.5 1500LB FLANGE
- AB ANSI B16.5 2500LB FLANGE
- D6 DIN2527 PN6 FLANGE
- D0 DIN2527 PN10 FLANGE
- D1 DIN2527 PN16 FLANGE
- D2 DIN2527 PN25 FLANGE
- D4 DIN2527 PN40 FLANGE
- J5 JIS 5K FLANGE
- J0 JIS 10K FLANGE
- J1 JIS 16K FLANGE
- J2 JIS 20K FLANGE
- J4 JIS 40K FLANGE
- S1 AS 2129 Table D
- S2 AS 2129 Table E
- S3 AS 2129 Table F
- S4 AS 2129 Table H

F 2 D4

Tank Fastening Kits For Probes

Flexible Probes (316L)

CGR-A0X-WL-SS

Rigid Probes (316L)

CGR-B0X-PL-SS

Centering Discs

Centering disc will add 50mm (2") to the end of the probe

CGR-CDAAXX-11-PK

Centering Disc Kit For 11mm Probe (PEEK)

CGR-CDAAXX-11-PT

Centering Disc Kit For 11mm Probe (PTFE)

CGR-CDAAXX-11-S6

Centering Disc Kit For 11mm Probe (316L)

CGR-CDAAXX-11-MN

Centering Disc Kit For 11mm Probe (Monel 400)

Specifications

Centurion Guided Radar



Specifications dependent on model selection.

Electronics

Power

- 2 wire loop powered
- 24VDC (14 to 28VDC)
- Ethernet Powered (48VDC)

Power Consumption

- <500mW @ 24VDC

Analog Output

- 14V @ 0 Ohm
- 19V @ 250 Ohms
- 24V @ 500 Ohms
- Current park at 4mA, 8mA, 12mA

Communications

- HART (Revision 7)
- GoshawkII via HART, Modbus, Ethernet
- Ethernet
- HawkEye365

Maximum Range

- Flexible cable probe: 38m (124ft)
- Rigid probe: 4m (13ft 1in)
- Segmented Rigid probe (B11 type): 6m (13ft 1in)

Minimum Range (Blanking)

- <=150mm (6.0")

Dielectric Range

- ≥ 1.5 (Interface mode requires low to high dielectric layers)

Frequency

- 2.2 GHz

Resolution

- Analog: 1uA
- Display: 1.0mm

Accuracy

- +/- 3mm

Measurements Per Second

- 3

Response Time

- <1 second (application dependant)

Sum of Non Linearity, Non repeatability, Hysteresis

- Analog +/- 0.02%

Repeatability

- +/- 3mm

Memory

- Non-Volatile (No backup battery required)
- >10 years data retention

Operating Temperature (Electronics)

- -40°C to +80°C (-40°F to +176°F)

Display

- 4 line graphic display (128 x 64 pixels)

Language

- English

Configuration

- 4 button (up down, Cal, Run), GoshawkII via HART. HART 7 DD/DTM

Approvals

- **Certificate No. IECEx TSA 14.0037X**
IECEx Zone 0/1, Zone 1
Ex ia/d [ia Ga] IIC T6...T2 Ga/Gb Tamb = -40°C to +60°C
IECEx Zone 20/21
Ex ia tb [ia Da] IIIC T85°C...T255°C Da Db Tamb = -40°C to +60°C
- **Certificate No. FM18US0194X**
FM Class I Div 1 & Class I, Zone 0/1
XP Cl. I Div 1 Gp B-D with IS Probe Cl. I, Div I, Gp A-D, T6...T2B Ta = -**°C to +60°C
Cl. I, Zone 0/1 AEx ia/db IIC T6...T2 Ga/Gb Ta = -**°C to +60°C
FM Class II,III Div 1 & Zone 20/21
DIP-IS Class II, III, Division 1, Groups E,F and G T6...T2B Ta = -**°C to +60°C
Zone 20/21 AEx ia IIIC T85°C...T255°C Da; AEx tb IIIC T85°C Db, Ta = -**°C to +60°C
- **Certificate No. FM18CA0091X**
CSA Class I Div 1
XP-AIS Cl. I Div 1 Grp B-D with IS Probe Cl. I, Div I, GP A-D, T6...T2B
Ta = -**°C to +60°C
CSA Class I, Zone 0/1
Ex ia/db IIC T6...T2 Ga/Gb Ta = -**°C to +60°C
CSA Class II,III Div 1
DIP-IS Cl. II,III Div 1 Groups E, F and G T6...T2B Ta = -**°C to +60°C
CSA Zone 20/21
Ex ia IIIC T85°C...T250°C Da; Ex tb T85°C, Db Ta = -**°C to +60°C
- **Certificate No. FM18ATEX0046X**
ATEX Ex II 1/2 G Ex ia/db IIC T6...T2 Ga/Gb Ta = -**°C to +60°C
ATEX Ex II 1/2 D Ex ia IIIC T85°C...T250°C Da; Ex tb IIIC T85°C Db
Ta = -**°C to +60°C
- **Certificate No. FM18NUS0014**
FM General Purpose
FM Class 3810: 2018, ANSI/ISA 61010-1: 2012, ANSI/NEMA 250:2003,
ANSI/IEC 60529:2004
- **Certificate No. FM18NCA0005**
CSA General Purpose
CSA-C22.2 No. 94:2011, CSA-C22.2 No. 60529: 2010, CAN/
CSA-C22.2 No. 61010-1:2012
- **Self Declaration**
ATEX II 3 D Ex ia IIIC T85°C...T255°C Dc Tamb -40°C to 60°C, Ex tb
IIIC T85°C Dc5
ATEX II 3 G Ex ic/dc IIC T6... T2 Gc Tamb -40°C to 60°C
ATEX II 3 D Ex tc IIIC T85°C ... T250°C Dc Tamb -40°C to 60°C Ex tb
IIIC T85°C Dc

**Refer to Safety Instructions

Specifications

Centurion Guided Radar



Specifications dependent on model selection.

Electromagnetic Compatibility



CAN ICES-3(A)/NMB-3(A)

This device complies with Part 15, Subpart B Class A of the FCC Rules. Operation is subject to the following two conditions: (1) This device may not cause harmful interference, and (2) this device must accept any interference received, including interference that may cause undesired operation.

Note: This equipment has been tested and found to comply with the limits for a Class A digital device, pursuant to part 15 of the FCC rules. These limits are designed to provide reasonable protection against harmful interference when the equipment is operated in a commercial environment. This equipment generates, uses and can radiate radio frequency energy and, if not installed and used in accordance with the instruction manual, may cause harmful interference to radio communications. Operation of this equipment in a residential area is likely to cause harmful interference in which case the user will be required to correct the interference at his own expense.

SIL Rating

- Certificate No. 968/FSP 1375.01/18
- SIL2 • SIL3 (multi channel)

Enclosure

Type

- Dual Chamber with viewing window
- Single Chamber with or without viewing window

Material

- Die-cast Copper-Free Aluminium, Epoxy Painted
- 316L Stainless

Conduit / Cable Entry

- 1/2" NPT • M20 x 1.5

IP Rating

- NEMA 4X
- IP66

Probe

Probe Size / Material

- 4mm SS316L / Monel 400 rod
- 4mm DIN3055 (7x7 strand) SS316L flexible cable / PTFE coated
- 6mm SS316L / Monel 400 rod
- 6mm DIN3055 (7x7 strand) SS316L flexible cable / PTFE coated
- 8mm SS316L / Monel 400 rod
- 8mm DIN3055 (7x7 strand) SS316L flexible cable / PTFE coated
- 11mm SS316L / Monel 400 rod

Wetted Materials²

- TN07 / TB07 / TN10 / TB10 / Integrated Flange¹ SS316L / Monel, PEEK
- TN15 / TB15 / Integrated Flange¹ - SS316L / Monel, PTFE, GF25

¹ See Probe / Mounting Combination Table for flange types

Probe O-Ring Seals / Process Temperature*

- FKM (Viton) -40°C to +150°C (-40°F to +302°F)
- EPDM -40°C to +130°C (-40°F to +266°F)
- FFKM (Markez) -10°C to +200°C (+14°F to +392°F)
- FFKM (Markez) -5°C to +325°C (+23°F to +617°F)
- Silicone -40°C to +80°C (-40°F to +176°F)
- Silicone -40°C to +130°C (-40°F to +266°F)
- NBR -40°C to +80°C (-40°F to +176°F)

Process Connections

- 3/4" NPT • 1" NPT • 1.5" NPT
- 3/4" BSP • 1" BSP • 1.5" BSP
- Threaded Flange
- Integrated Flange

Process Pressure

- -1 to 100 BAR

Tensile Load (flexible cable probes)

- Probe Type: A04 / J04 0.5 ton
- Probe Type: A06 / J06 1.0 ton
- Probe Type: A08 / J08 4.0 ton

Lateral Load (Rigid Probes)

- Probe Type: B04 / K04 1 Nm
- Probe Type: B06 / K06 3 Nm
- Probe Type: B08 / K08 8 Nm
- Probe Type: B11 11 Nm

Probe Length Max Min

- Probe Type: A04 / J04 3800cm 100cm
- Probe Type: A06 / J06 3800cm 100cm
- Probe Type: A08 / J08 3800cm 100cm
- Probe Type: B04 / K04 400cm 20cm
- Probe Type: B06 / K06 400cm 20cm
- Probe Type: B08 / K08 400cm 20cm
- Probe Type: B11 600cm 20cm

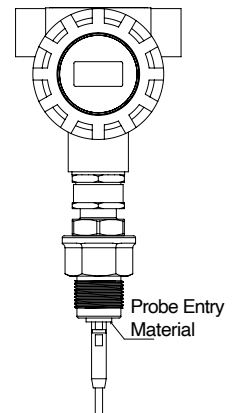

² PEEK or PTFE/GF25 probe entry



Ordering Instructions

Threaded unit type

Assemble part number taking note of the valid combinations and exclusions for the full system. The unit is ordered as a single line item. For example:

CGR2H13B08STB15B11XX200

Flanged type - Threaded flange

Assemble part number taking note of the valid combinations and exclusions for the full system. The unit and the threaded flange are ordered as separate line items.

For example:

CGR2H13B08STN15B11XX200

FLA-FA4-SS-TN15

or

CGR2H13B08STN07B11XX200

FLA-FA1-SS-TN07

Flanged Bush type

Assemble part number taking note of the valid combinations and exclusions for the full system. In the Mounting part code enter 4 character Integrated flange code from the table. All Integrated flanges have F as the first character. For example.

CGR2H13B08SF4A1B11XX200